

---

# INSTALLATION INSTRUCTIONS

---

## WALL MOUNTED PACKAGE AIR CONDITIONERS

### MODELS

<b>J17A2</b>	<b>J17L2</b>
<b>J24A2</b>	<b>J24L2</b>
<b>J30A2</b>	<b>J30L2</b>
<b>J36A2</b>	<b>J36L2</b>
<b>J42A2</b>	<b>J42L2</b>
<b>J48A2</b>	<b>J48L2</b>
<b>J60A2</b>	<b>J60L2</b>
<b>J70A2</b>	<b>J70L2</b>



Manual : 2100-588A  
Supersedes: 2100-588  
File: Volume III Tab 16  
Date: 03-05-14

# Contents

---

## Getting Other Information and Publications 3

### Wall Mount General Information

Wall Mount Model Nomenclature .....	4
Shipping Damage .....	4
General .....	4
Duct Work .....	5
Filters .....	5
Fresh Air Intake .....	5
Condensate Drain .....	5

### Installation Instructions

Wall Mounting Information .....	6
Mounting the Unit.....	6
Clearances Required .....	6
Minimum Clearances .....	6
Wiring – Main Power.....	14
Wiring – Low Voltage Wiring.....	14

### Figures

Figure 1 Fresh Air Damper Assembly.....	5
Figure 2 Unit Dimensions .....	7
Figure 3A Mounting Instructions J17-24 .....	8
Figure 3B Mounting Instructions J30 – 36 .....	9
Figure 3C Mounting Instructions J42, 48, 60, 70.....	10
Figure 4 Electric Heat Clearance .....	11
Figure 5 Wall Mounting Instructions .....	12
Figure 6 Wall Mounting Instructions .....	12
Figure 7 Common Wall Mounting Installations .....	13
Figure 8 Basic A/C w/Opt. Elec. Heat (No Econ) .....	15
Figure 9 Basic A/C w/Opt. Elec. Heat (EIFM Econ) .....	18
Figure 10 Basic A/C w/Opt. Elec. Heat (Newer Econ).....	18
Figure 11 Fan Blade Setting.....	21

### Start Up

General .....	18
Topping Off System Charge.....	18
Safety Practices .....	18
Important Installer Note.....	19
High Pressure Switch.....	19
Three Phase Scroll Compressor.....	19
Phase Monitor.....	19
Condenser Fan Operation .....	19
Service Hints.....	19
Sequence of Operation .....	20
Compressor Control Module .....	20
Adjustments .....	20
Pressure Service Ports .....	20

### Troubleshooting

Fan Blade Setting Dimensions.....	21
R-410A Refrigerant Charge .....	21
Removal of Fan Shroud.....	21

### Tables

Table 1 Fan Blade Dimensions .....	21
Table 2 Refrigerant Charge.....	21
Table 3 Refrigerant Charge.....	21
Table 4 Cooling Pressure.....	22
Table 5 Electrical Specifications J**A.....	24
Table 6 Electrical Specifications J**L.....	24
Table 7 Recommended Airflow .....	25
Table 8 Indoor Blower Performance .....	25
Table 9 Maximum ESP Electric Heat Only.....	25
Table 10 Electric Heat.....	26
Table 11A Optional Accessories — Right Hand .....	27
Table 11B Optional Accessories — Left Hand .....	28
Table 12 Vent & Control Options.....	29

---

## GETTING OTHER INFORMATION AND PUBLICATIONS

---

These publications can help you install the air conditioner or heat pump. You can usually find these at your local library or purchase them directly from the publisher. Be sure to consult current edition of each standard.

National Electrical Code ..... ANSI/NFPA 70

Standard for the Installation ..... ANSI/NFPA 90A  
of Air Conditioning and Ventilating Systems

Standard for Warm Air ..... ANSI/NFPA 90B  
Heating and Air Conditioning Systems

Load Calculation for ..... ACCA Manual J  
Residential Winter and Summer Air Conditioning

Duct Design for Residential ..... ACCA Manual D  
Winter and Summer Air Conditioning and Equipment  
Selection

### FOR MORE INFORMATION, CONTACT THESE PUBLISHERS:

**ACCA**     **Air Conditioning Contractors of America**  
1712 New Hampshire Ave. N.W.  
Washington, DC 20009  
Telephone: (202) 483-9370  
Fax: (202) 234-4721

**ANSI**     **American National Standards Institute**  
11 West Street, 13th Floor  
New York, NY 10036  
Telephone: (212) 642-4900  
Fax: (212) 302-1286

**ASHRAE**   **American Society of Heating, Refrigeration  
and Air Conditioning Engineers, Inc.**  
1791 Tullie Circle, N.E.  
Atlanta, GA 30329-2305  
Telephone: (404) 636-8400  
Fax: (404) 321-5478

**NFPA**     **National Fire Protection Association**  
Batterymarch Park  
P.O. Box 9101  
Quincy, MA 02269-9901  
Telephone: (800) 344-3555  
Fax: (617) 984-7057

# WALL MOUNT GENERAL INFORMATION

## AIR CONDITIONER WALL MOUNT MODEL NOMENCLATURE

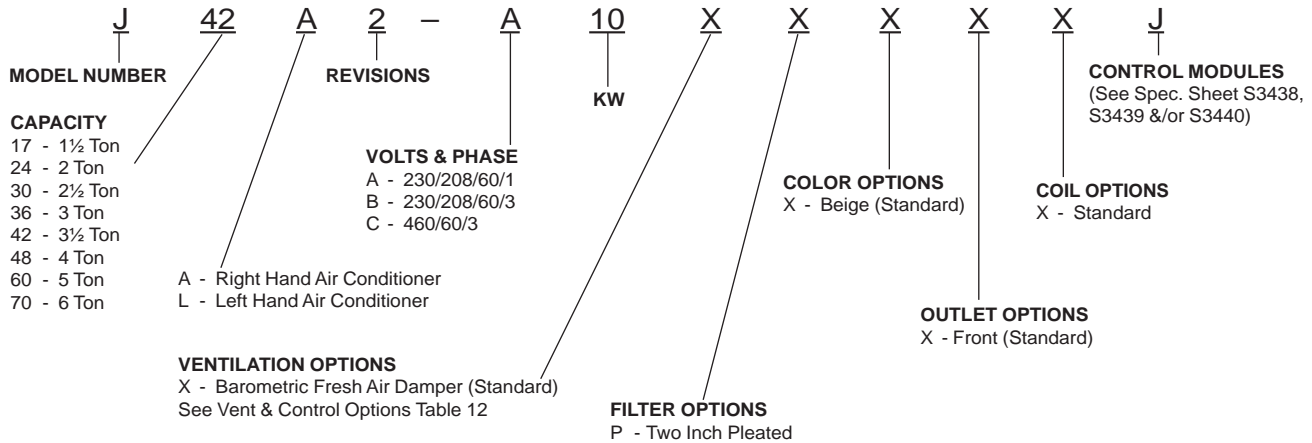

*NOTE: Vent option X is without exhaust capability. May require separate field supplied barometric relief in building.*

### SHIPPING DAMAGE

Upon receipt of equipment, the carton should be checked for external signs of shipping damage. If damage is found, the receiving party must contact the last carrier immediately, preferably in writing, requesting inspection by the carrier’s agent.

### GENERAL

The equipment covered in this manual is to be installed by trained, experienced service and installation technicians.

The refrigerant system is completely assembled and charged. All internal wiring is complete.

The unit is designed for use with or without duct work. Flanges are provided for attaching the supply and return ducts.

These instructions explain the recommended method to install the air cooled self-contained unit and the electrical wiring connections to the unit.

These instructions and any instructions packaged with any separate equipment required to make up the entire air conditioning system should be carefully read before beginning the installation. Note particularly “Starting Procedure” and any tags and/or labels attached to the equipment.

While these instructions are intended as a general recommended guide, they do not supersede any national and/or local codes in any way. Authorities having jurisdiction should be consulted before the installation is made. See Page 3 for information on codes and standards.

Size of unit for a proposed installation should be based on heat loss calculation made according to methods of Air Conditioning Contractors of America (ACCA). The air duct should be installed in accordance with the Standards of the National Fire Protection Association for the Installation of Air Conditioning and Ventilating Systems of Other Than Residence Type, NFPA No. 90A, and Residence Type Warm Air Heating and Air Conditioning Systems, NFPA No. 90B. Where local regulations are at a variance with instructions, installer should adhere to local codes.

## DUCT WORK

All duct work, supply and return, must be properly sized for the design airflow requirement of the equipment. Air Conditioning Contractors of America (ACCA) is an excellent guide to proper sizing. All duct work or portions thereof not in the conditioned space should be properly insulated in order to both conserve energy and prevent condensation or moisture damage.

Refer to Maximum ESP of operation Electric Heat Table 9.

Design the duct work according to methods given by the Air Conditioning Contractors of America (ACCA). When duct runs through unheated spaces, it should be insulated with a minimum of one inch of insulation. Use insulation with a vapor barrier on the outside of the insulation. Flexible joints should be used to connect the duct work to the equipment in order to keep the noise transmission to a minimum.

Models J17 - J24 as approved for zero inch clearance to the supply duct. For model series J30, J36, J42, J48, J60 and J70 a 1/4 inch clearance to combustible material for the first three feet of duct attached to the outlet air frame is required. See Wall Mounting Instructions and Figures 3A - 3C for further details.

Ducts through the walls must be insulated and all joints taped or sealed to prevent air or moisture entering the wall cavity.

Some installations may not require any return air duct. A metallic return air grille is required with installations not requiring a return air duct. The spacing between louvers on the grille shall not be larger than 5/8 inch.

Any grille that meets with 5/8 inch louver criteria may be used. It is recommended that Bard Return Air Grille Kit RG2 through RG5 or RFG2 through RFG5 be installed when no return duct is used. Contact distributor or factory for ordering information. If using a return air filter grille, filters must be of sufficient size to allow a maximum velocity of 400 fpm.

*NOTE: If no return air duct is used, applicable installation codes may limit this cabinet to installation only in a single story structure.*

## FILTERS

A two-inch pleated filter is standard with each unit. The internal filter brackets are adjustable to accommodate the 2-inch filter by bending two (2) tabs down on each side of the filter support bracket.

## FRESH AIR INTAKE

All units are built with fresh air inlet slots punched in the service door.

If the unit is equipped with a fresh air damper assembly, the assembly is shipped already attached to the unit. The damper blade is locked in the closed position. To allow the damper to operate, the maximum and minimum blade position stops must be installed. See Figure 1.

All capacity, efficiency and cost of operation information is based upon the fresh air blank-off plate in place and is recommended for maximum energy efficiency.

The blank-off plate is available upon request from the factory and is installed in place of the fresh air damper shipped with each unit.

## CONDENSATE DRAIN

A plastic drain hose extends from the drain pan at the top of the unit down to the unit base. There are openings in the unit base for the drain hose to pass through. In the event the drain hose is connected to a drain system of some type, it must be an open or vented type system to assure proper drainage.

**FIGURE 1  
FRESH AIR DAMPER**

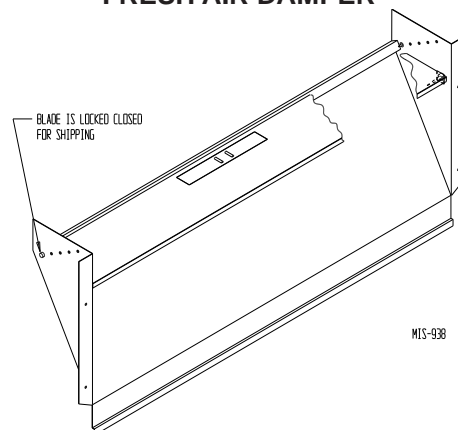

# INSTALLATION INSTRUCTIONS

## WALL MOUNTING INFORMATION

1. Two holes for the supply and return air openings must be cut through the wall as shown in Figures 3A-3C.
2. On wood frame walls, the wall construction must be strong and rigid enough to carry the weight of the unit without transmitting any unit vibration.
3. Concrete block walls must be thoroughly inspected to insure that they are capable of carrying the weight of the installed unit.



## WARNING

Failure to provide the 1/4 inch clearance between the supply duct and a combustible surface for the first 3 feet of duct can result in fire causing damage, injury or death.

## MOUNTING THE UNIT

1. These units are secured by wall mounting brackets which secure the unit to the outside wall surface at both sides. A bottom mounting bracket, attached to skid for shipping, is provided for ease of installation, but is not required.
2. Models J17 and J24 are suitable for 0 inch clearance to the unit and the supply air duct. Models J30-J70 require 1/4 inch clearance to combustible materials to the supply air duct flange and the first 3 feet of supply air duct. However, it is generally recommended that a 1-inch clearance is used for ease of installation and maintaining the required clearance to combustible material. See Figure 3 for details on opening sizes.
3. Locate and mark lag bolt locations and bottom mounting bracket location. See Figures 3A - 3C.
4. Mount bottom mounting bracket.
5. Hook top rain flashing, attached to front - right of supply flange for shipping, under back bend of top.
6. Position unit in opening and secure with 5/16 lag bolts; use 7/8 inch diameter flat washers on the lag bolts.
7. Secure rain flashing to wall and caulk across entire length of top. See Figures 3A - 3C.
8. For additional mounting rigidity, the return air and supply air frames or collars can be drilled and screwed or welded to the structural wall itself (depending upon wall construction). Be sure to observe required clearance if combustible wall.
9. On side-by-side installations, maintain a minimum of 20 inches clearance on right side to allow access to control panel and heat strips, and to allow proper airflow to the outdoor coil. Additional clearance may be required to meet local or national codes.

### ***Clearances Required for Service Access and Adequate Condenser Airflow***

MODELS	LEFT SIDE	RIGHT SIDE	DISCHARGE SIDE
J17A, J24A, J30A, J36A	15"	20"	10'
J17L, J24L, J30L, J36L	20"	15"	10'
J42A, J48A, J60A, J70A	20"	20"	10'
J42L, J48L, J60L, J70L	20"	20"	10'

NOTE: For side by side installation of two (2) J\*\*A models there must be 20" between units. This can be reduced to 15" by using a J\*\*L model (left side compressor and controls) for the left unit and JA (right side compressor and controls) for right unit.

See J\*\*A Specification S3438 & J\*\*L Specification S3439 & J70 Specification S3440 (Right & Left-Hand).

### ***Minimum Clearances Required to Combustible Materials***

MODELS	SUPPLY AIR DUCT FIRST THREE FEET	CABINET
J17A, L / J24A, L	0"	0"
J30A, L / J36A, L	1/4"	0"
J42A, L / J48A, L J60A, L / J70A, L	1/4"	0"

FIGURE 2

**Dimensions of Basic Unit for Architectural and Installation Requirements (Nominal)**

MODEL	WIDTH (W)	DEPTH (D)	HEIGHT (H)	SUPPLY		RETURN																
				A	B	C	B	E	F	G	I	J	K	L	M	N	O	P	Q	R	S	T
J17A, L J24A, L	33.300	17.125	70.563	7.88	19.88	11.88	19.88	35.00	11.00	25.75	20.56	26.75	28.06	29.25	27.00	2.63	34.13	22.06	10.55	4.19	12.00	5.00
J30A, L J36A, L	38.200	17.125	70.563	7.88	27.88	13.88	27.88	40.00	11.00	25.75	17.93	26.75	28.75	29.25	27.00	2.75	39.19	22.75	9.14	4.19	12.00	5.00
J42A, L J48A, L J60A, L J70A, L	42.075	22.432	84.875	9.88	29.88	15.88	29.88	43.88	13.63	31.66	30.00	32.68	26.94	34.69	32.43	3.37	42.88	23.88	10.00	1.44	16.00	1.88

All dimensions are in inches. Dimensional drawings are not to scale.

**J\*\*A  
RIGHT  
UNIT**

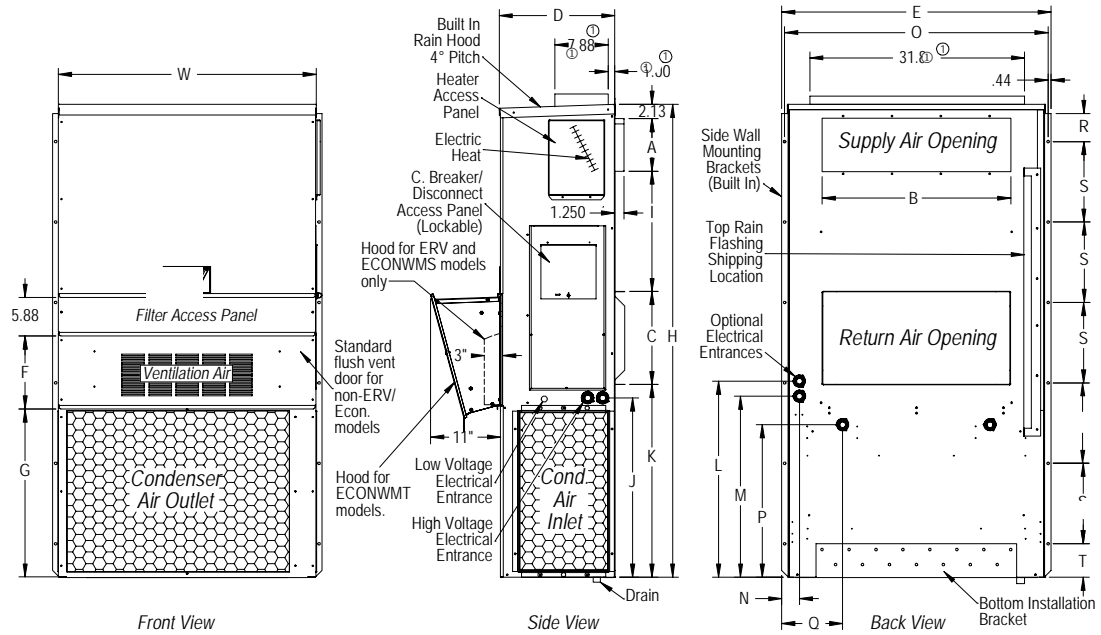

MS-2487 H

① Optional top outlet (factory installed only) for J30A and J36A models only.

**J\*\*L  
LEFT  
UNIT**

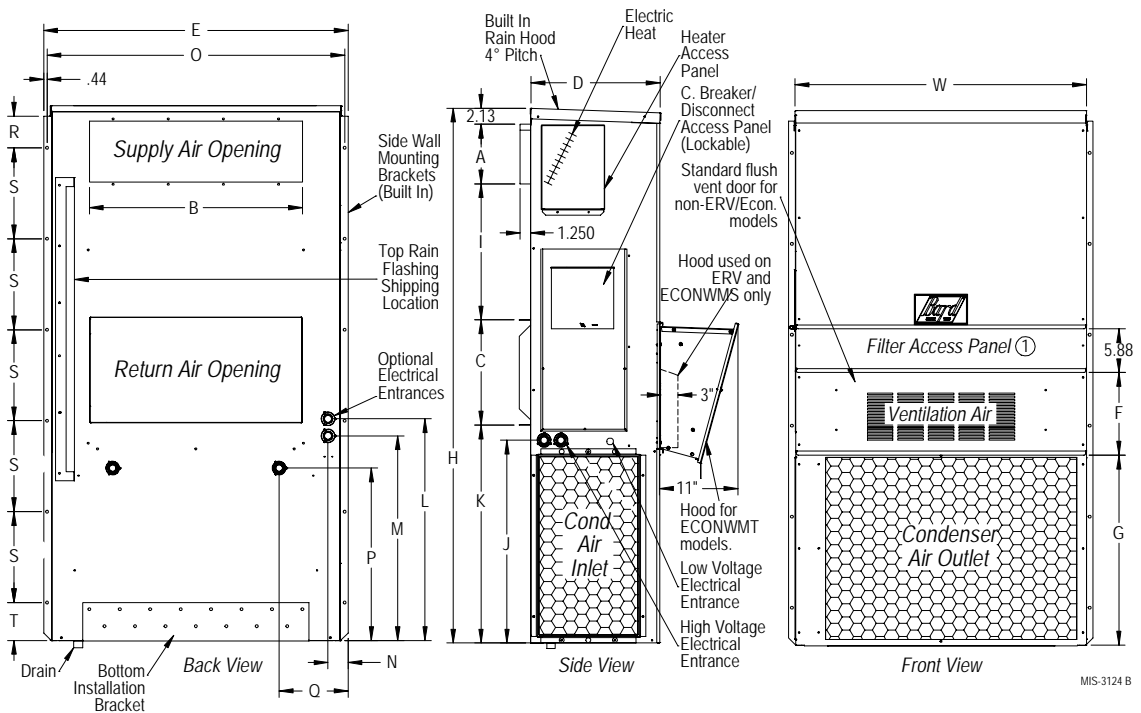

MS-3124 B







**FIGURE 3C**  
**J42A2, J42L2, J48A2, J48L2, J60A2, J60L2, J70A2, J70L2**  
**MOUNTING INSTRUCTIONS**

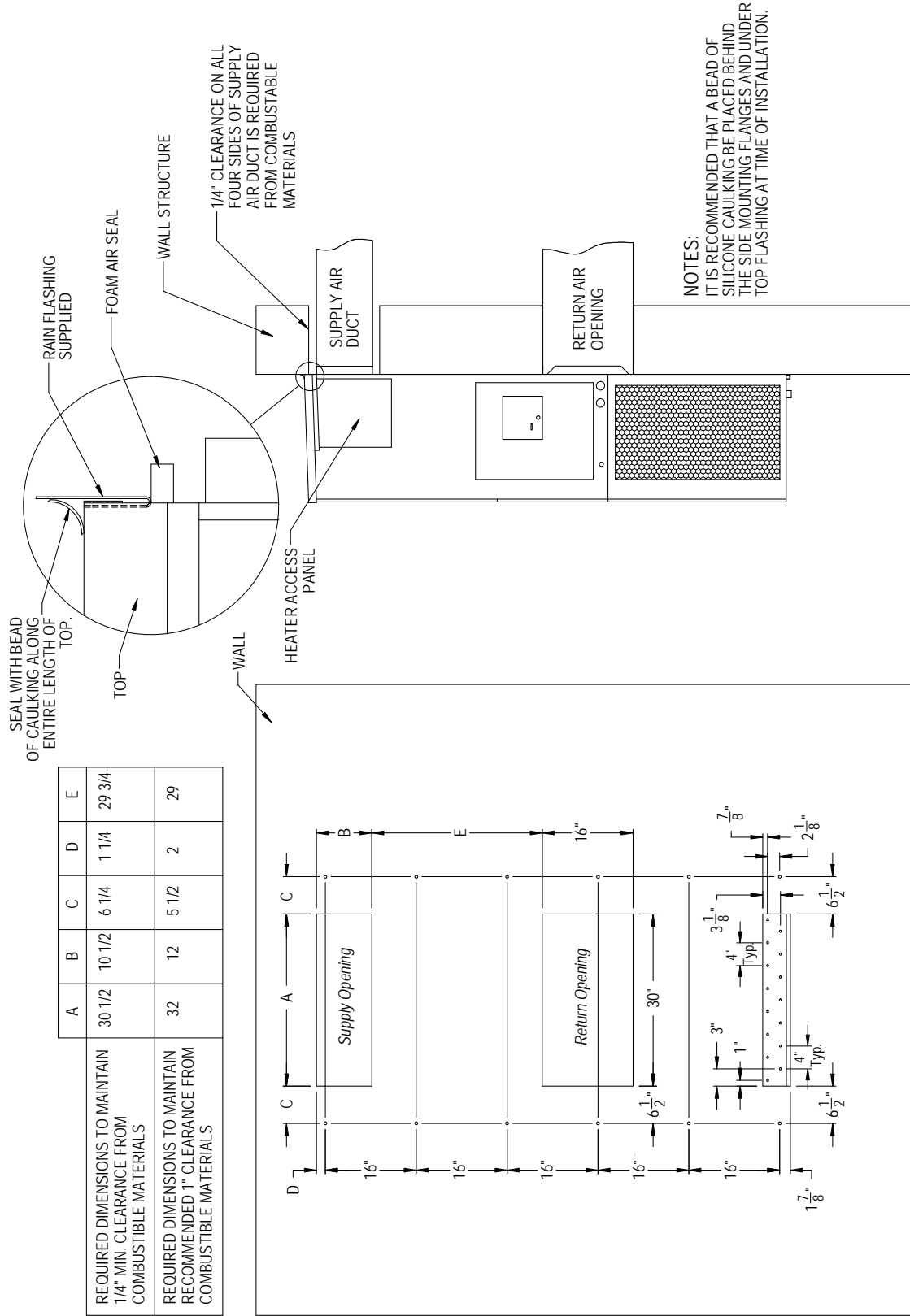

Right Side View

Wall Opening and Hole Location View

**FIGURE 4**  
**ELECTRIC HEAT CLEARANCE**  
J30A2, J30L2, J36A2, J36L2, J42A2, J42L2, J48A2, J48L2, J60A2, J60L2, J70A2, J70L2

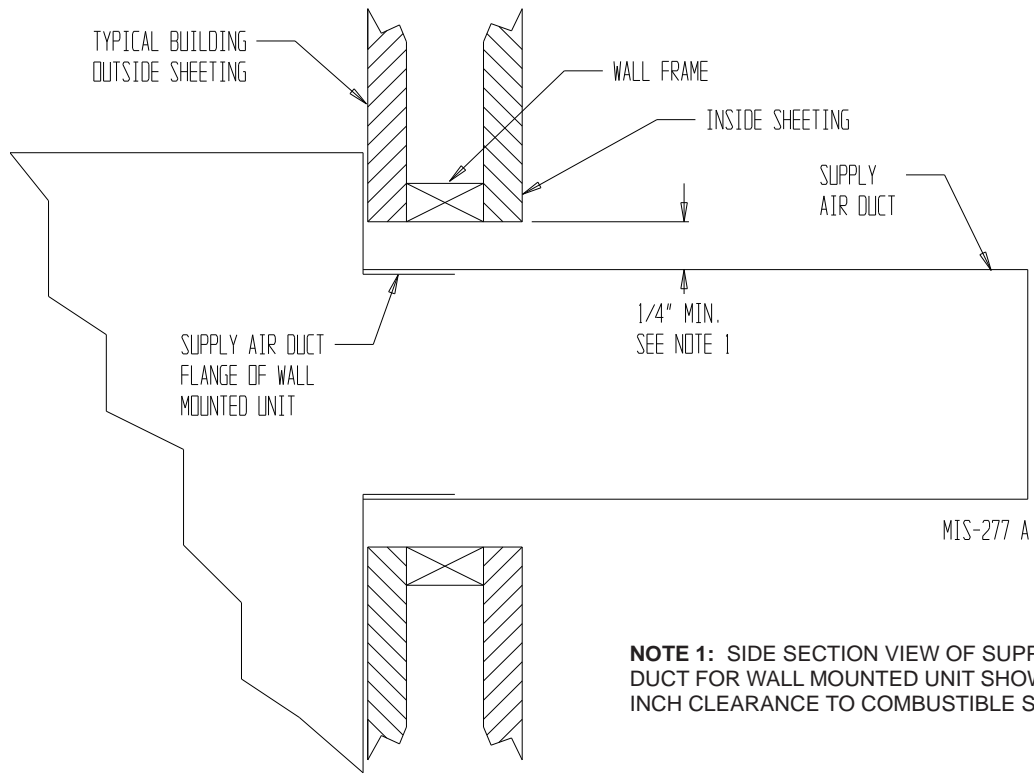

**NOTE 1:** SIDE SECTION VIEW OF SUPPLY AIR DUCT FOR WALL MOUNTED UNIT SHOWING 1/4 INCH CLEARANCE TO COMBUSTIBLE SURFACES.

## **WARNING**

A **minimum** of 1/4 inch clearance must be maintained between the supply air duct and combustible materials. This is required for the first 3 feet of ducting.

It is important to insure that the 1/4 inch minimum spacing is maintained at all points.

Failure to do this could result in overheating the combustible material and may result in a fire causing damage, injury or death.

## FIGURE 5 WALL MOUNTING INSTRUCTIONS

SEE FIGURES 3A-3C – MOUNTING INSTRUCTIONS

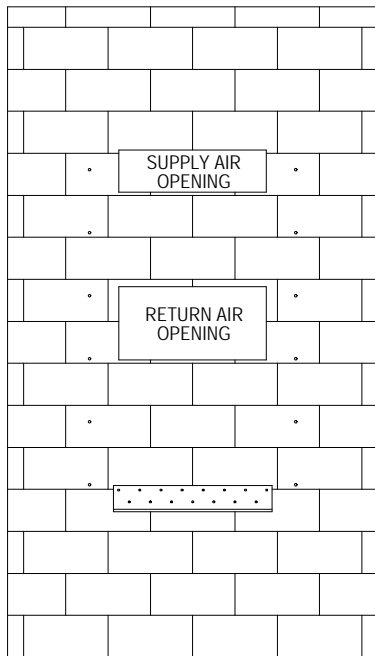

CONCRETE BLOCK WALL INSTALLATION

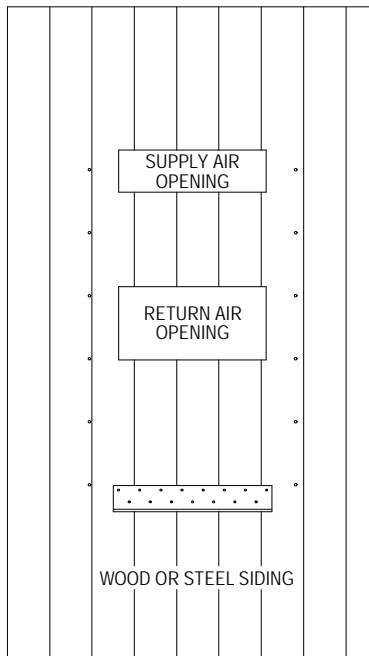

WOOD FRAME WALL INSTALLATION

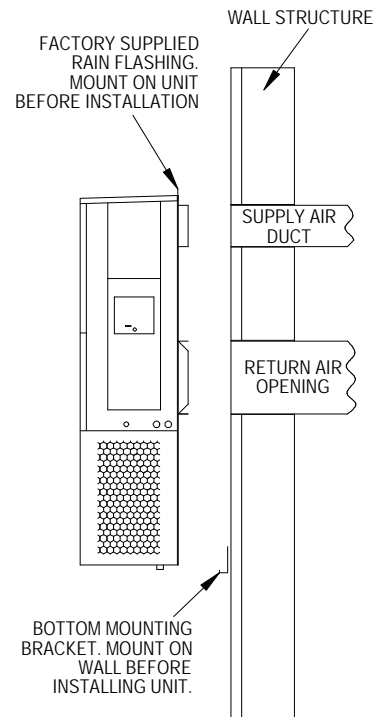

SIDE VIEW

MIS-548 A

## FIGURE 6 WALL MOUNTING INSTRUCTIONS

SEE UNIT DIMENSIONS, FIGURE 2,  
FOR ACTUAL DIMENSIONS.

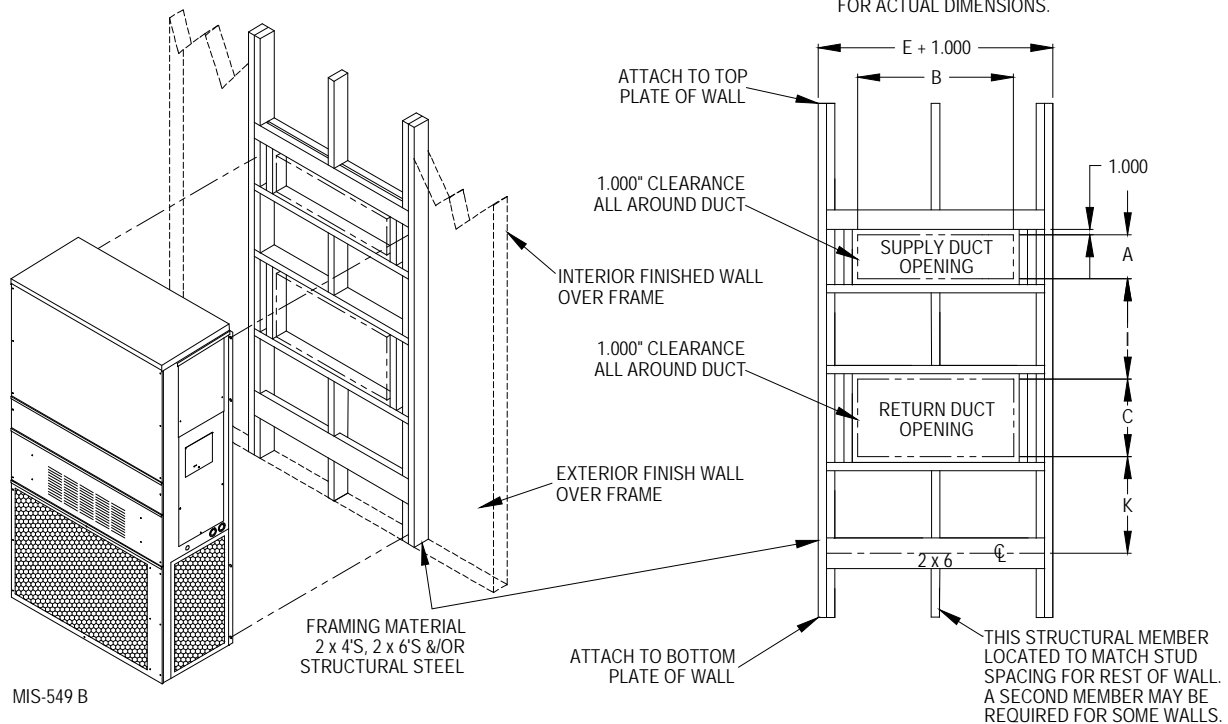

MIS-549 B

**FIGURE 7  
COMMON WALL MOUNTING INSTALLATIONS**

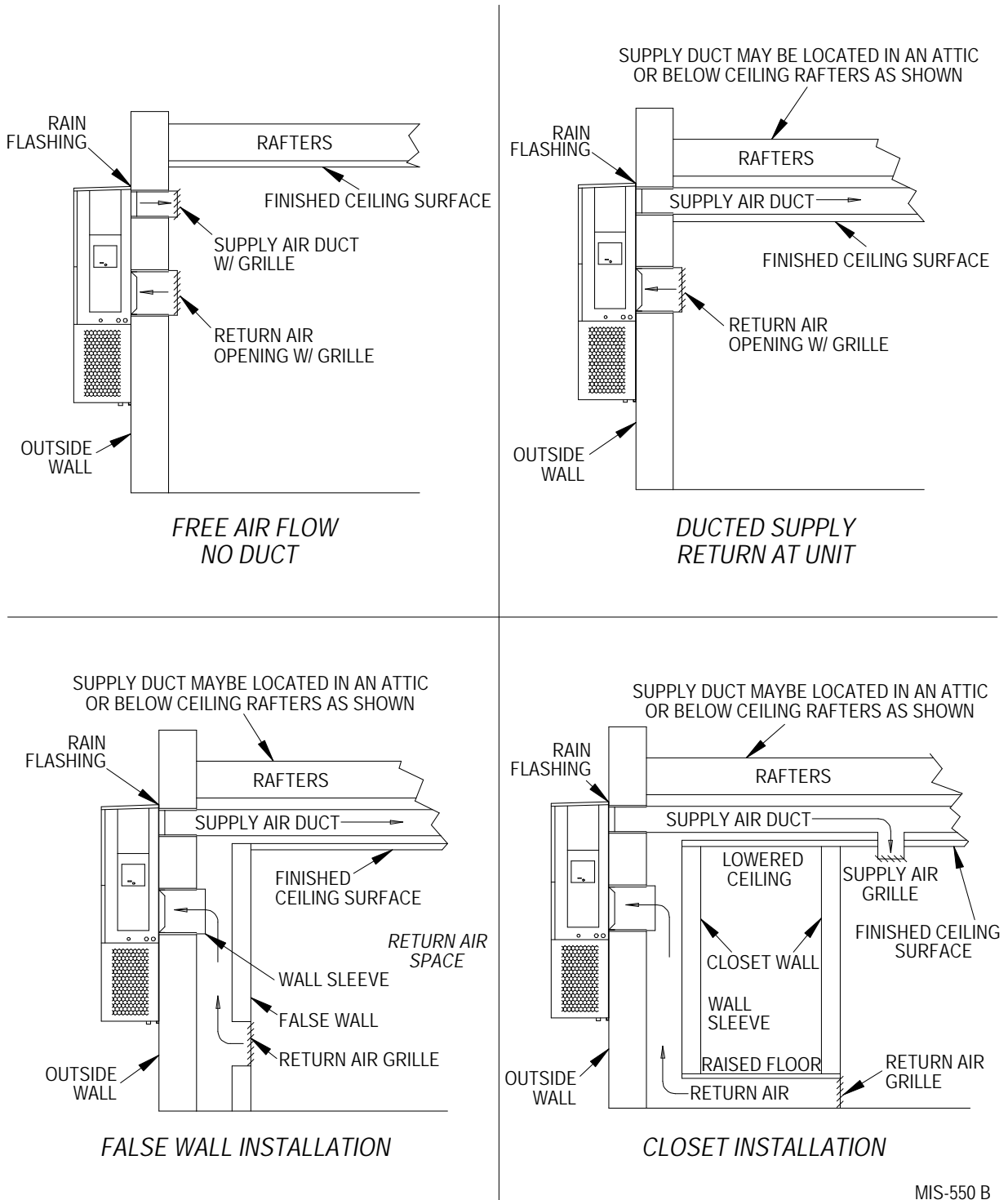

MIS-550 B

## WIRING – MAIN POWER

Refer to the unit rating plate for wire sizing information and maximum fuse or “HACR” type circuit breaker size. Each outdoor unit is marked with a “Minimum Circuit Ampacity”. This means that the field wiring used must be sized to carry that amount of current. Depending on the installed KW of electric heat, there may be two field power circuits required. If this is the case, the unit serial plate will so indicate. All models are suitable only for connection with copper wire. Each unit and/or wiring diagram will be marked “Use Copper Conductors Only”. These instructions **must be** adhered to. Refer to the National Electrical Code (NEC) for complete current carrying capacity data on the various insulation grades of wiring material. All wiring must conform to NEC and all local codes.

The electrical data lists fuse and wire sizes (75° C copper) for all models including the most commonly used heater sizes. Also shown are the number of field power circuits required for the various models with heaters.

The unit rating plate lists a “Maximum Time Delay Relay Fuse” or “HACR” type circuit breaker that is to be used with the equipment. The correct size must be used for proper circuit protection and also to assure that there will be no nuisance tripping due to the momentary high starting current of the compressor motor.

The disconnect access door on this unit may be locked to prevent unauthorized access to the disconnect. To convert for the locking capability, bend the tab located in the bottom left-hand corner of the disconnect opening under the disconnect access panel straight out. This tab will now line up with the slot in the door. When shut, a padlock may be placed through the hole in the tab preventing entry.

See “Start Up” section for important information on three phase scroll compressor start ups.

See Tables 5 & 6 for Electrical Specifications.

## WIRING – LOW VOLTAGE WIRING

All 230/208V, 1 phase and 3 phase equipment have dual primary voltage transformers. All equipment leaves the factory wired on 240V tap. For 208V operation, reconnect from 240V to 208V tap. The acceptable operating voltage range for the 240 and 208V taps are:

TAP	RANGE
240	253 – 216
208	220 – 187

*NOTE: The voltage should be measured at the field power connection point in the unit and while the unit is operating at full load (maximum amperage operating condition).*

An 18 gauge copper, color-coded thermostat cable is recommended. The connection points are shown in this Manual. See Table below.

### Low Voltage Connection

These units use a 24-volt AC low voltage circuit. The “RT” terminal is the 24V transformer output, and the “R” terminal is the 24VAC *hot* terminal for the operation of the equipment. “RT” and “R” are connected with brass jumper bar which can be removed and “RT” and “R” connected to external NC (normally closed) contact such as a fire/smoke detector that will cause immediate shutdown of the equipment upon activation.

“C” terminal is *grounded*.

“G” terminal is the *fan input*.

“Y” terminal is the *compressor input for cooling*.

“W1” terminal is the *1st stage electric heat*.

“W2” terminal is the *2nd stage heat* (if equipped).

“A” terminal is the *ventilation input*. This terminal energizes any factory installed ventilation option. See Table 14 for options.

**NOTE: Models with “J” Control Module, “3” terminal is used along with “1” and “2” for the alarm relay.**

### LOW VOLTAGE CONNECTIONS FOR DDC CONTROL

Fan Only	Energize G
Cooling Mode	Energize Y, G
1st Stage Heating	Energize W1
2nd Stage Heating (if employed)	Energize W1, W2
Ventilation	Energize G, A

**FIGURE 8**  
**BASIC A/C with OPTIONAL ELECTRIC HEAT**  
**NO ECONOMIZER**

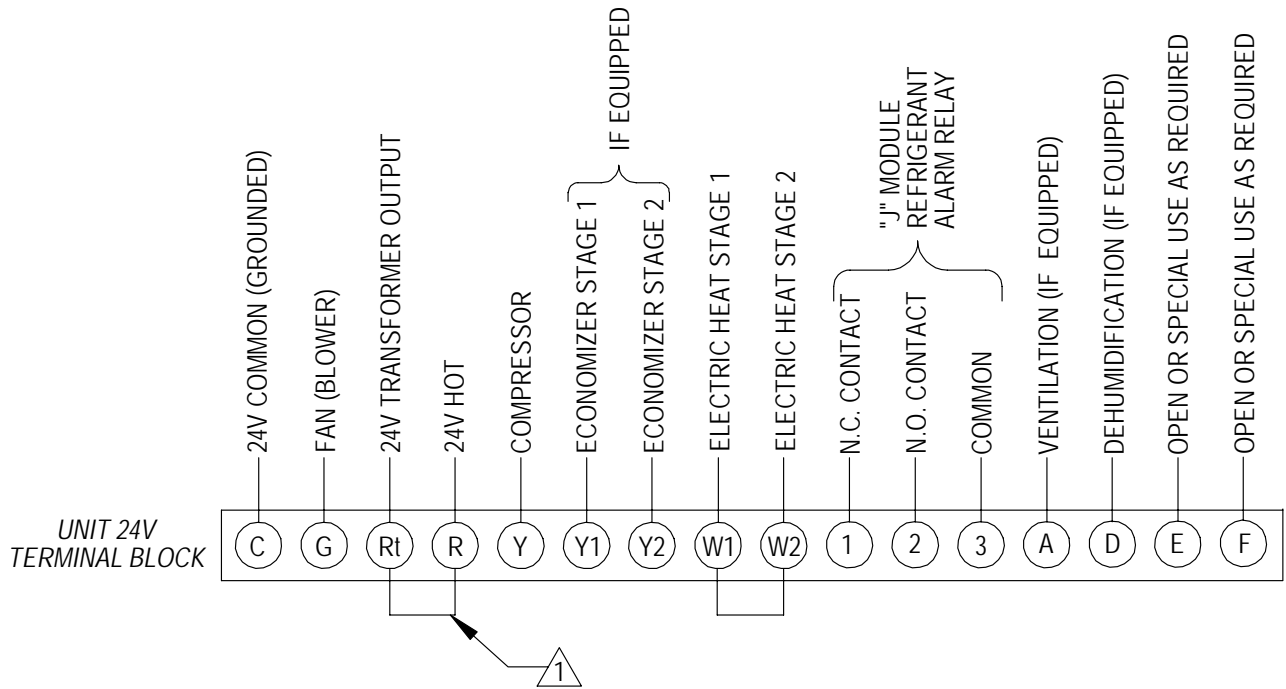

**1** FACTORY INSTALLED JUMPER FOR IMMEDIATE EMERGENCY SHUTDOWN OF ALL HVAC OPERATIONS, REMOVE JUMPER AND CONNECT NORMALLY CLOSED (NC) CONTACT TO R AND RT TERMINALS.

MIS-2975 A

**FIGURE 9**  
**BASIC A/C with OPTIONAL ELECTRIC HEAT**  
**OLDER EIFM STYLE ECONOMIZER**

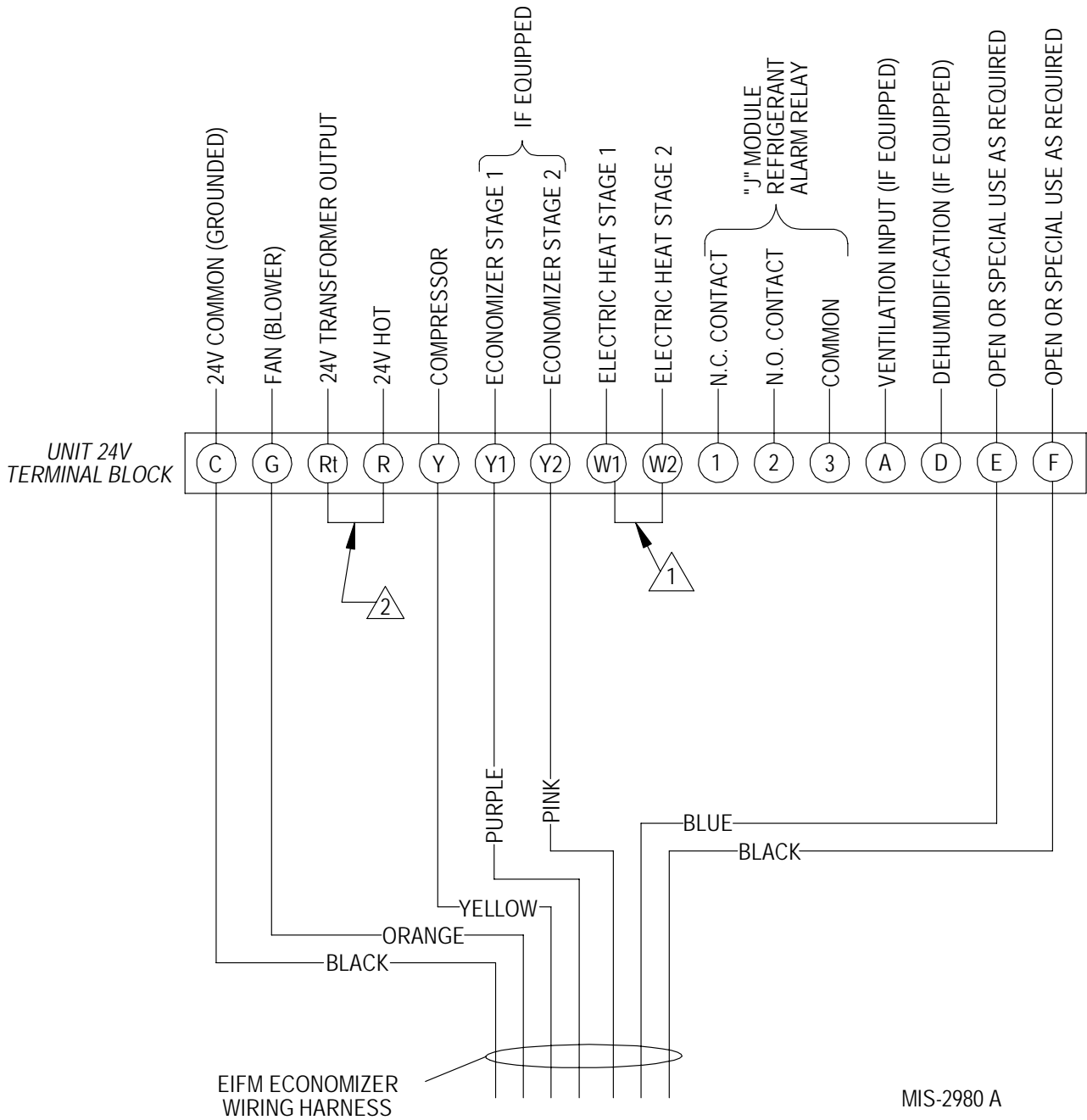

MIS-2980 A

**1** FACTORY INSTALLED JUMPER. REMOVE FOR 2-STAGE OPERATION ON UNITS WITH 15 OR MORE KW.

**2** FACTORY INSTALLED JUMPER FOR IMMEDIATE EMERGENCY SHUTDOWN OF ALL HVAC OPERATIONS, REMOVE JUMPER AND CONNECT NORMALLY CLOSED (NC) CONTACT TO R AND RT TERMINALS.



**FIGURE 10**  
**BASIC A/C with OPTIONAL ELECTRIC HEAT**  
**NEWER ECONWM\* STYLE ECONOMIZER**

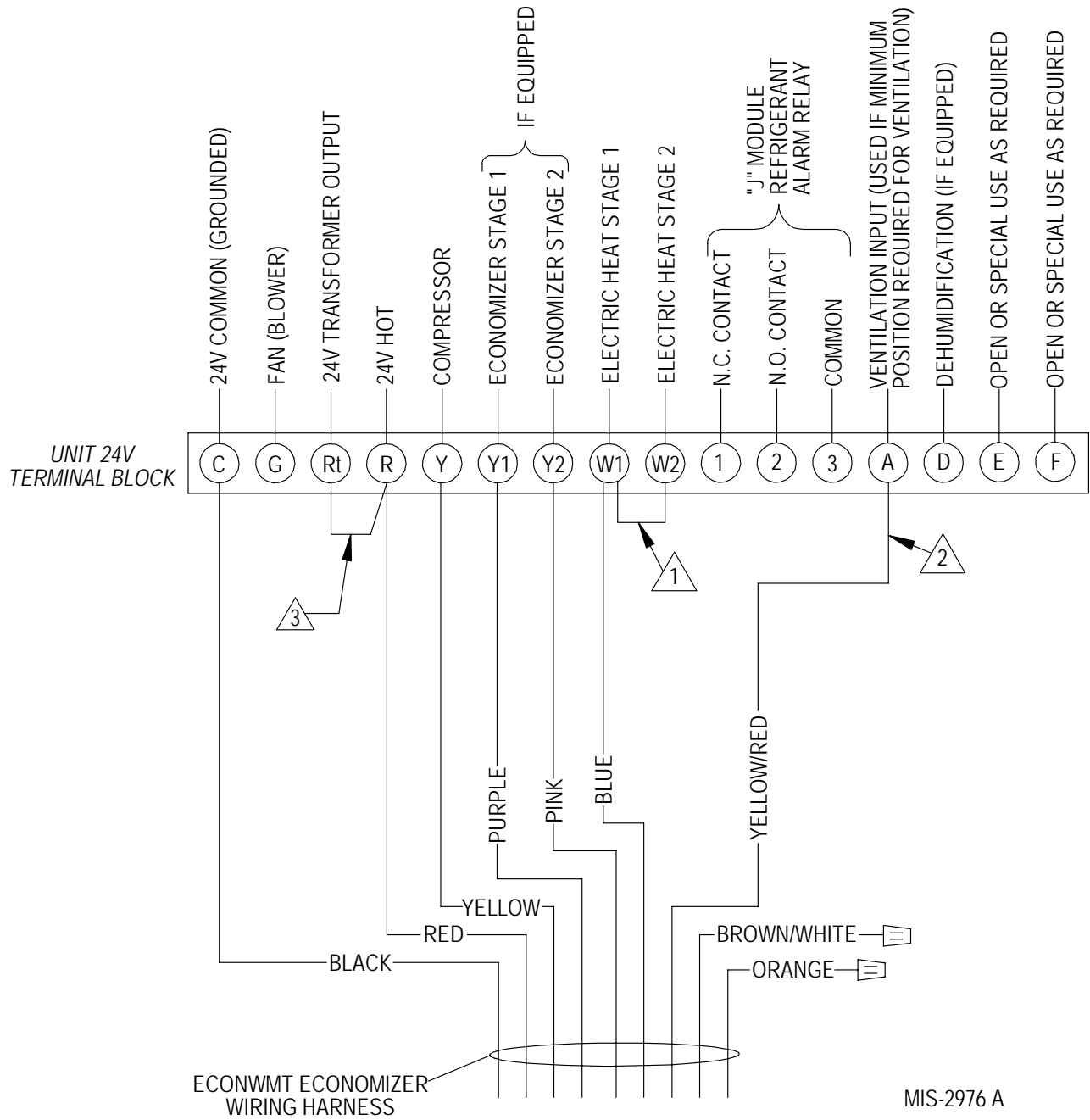

MIS-2976 A

- 1 FACTORY INSTALLED JUMPER. REMOVE FOR 2-STAGE OPERATION ON UNITS WITH 15 OR MORE KW.
- 2 MUST BE ENERGIZED TO ENABLE MINIMUM POSITION.
- 3 FACTORY INSTALLED JUMPER FOR IMMEDIATE EMERGENCY SHUTDOWN OF ALL HVAC OPERATIONS, REMOVE JUMPER AND CONNECT NORMALLY CLOSED (NC) CONTACT TO R AND RT TERMINALS.

# START UP

---

## THESE UNITS REQUIRE R-410A REFRIGERANT AND POLYOL ESTER OIL.

### GENERAL:

1. Use separate service equipment to avoid cross contamination of oil and refrigerants.
2. Use recovery equipment rated for R-410A refrigerant.
3. Use manifold gauges rated for R-410A (800 psi/250 psi low).
4. R-410A is a binary blend of HFC-32 and HFC-125.
5. R-410A is nearly azeotropic - similar to R-22 and R-12. Although nearly azeotropic, charge with liquid refrigerant.
6. R-410A operates at 40-70% higher pressure than R-22, and systems designed for R-22 cannot withstand this higher pressure.
7. R-410A has an ozone depletion potential of zero, but must be reclaimed due to its global warming potential.
8. R-410A compressors use polyolester oil.
9. Polyol Ester oil is hygroscopic; it will rapidly absorb moisture and strongly hold this moisture in the oil.
10. A liquid line dryer must be used - even a deep vacuum will not separate moisture from the oil.
11. Limit atmospheric exposure to 15 minutes.
12. If compressor removal is necessary, always plug compressor immediately after removal. Purge with small amount of nitrogen when inserting plugs.

### TOPPING OFF SYSTEM CHARGE

If a leak has occurred in the system, the Manufacturer recommends reclaiming, evacuating (see criteria above), and charging to the nameplate charge. If done correctly, topping off the system charge can be done without problems.

With R-410A, there are no significant changes in the refrigerant composition during multiple leaks and recharges. R-410A refrigerant is close to being an azeotropic blend (it behaves like a pure compound or single component refrigerant). The remaining refrigerant charge, in the system, may be used after leaks have occurred and then “top-off” the charge by utilizing the pressure charts on the inner control panel cover as a guideline.

REMEMBER: When adding R-410A refrigerant, it must come out of the charging cylinder/tank as a liquid to avoid any fractionation, and to ensure optimal system performance. Refer to instructions for the cylinder that is being utilized for proper method of liquid extraction.



## WARNING

***Failure to conform to these practices could lead to damage, injury or death.***

### SAFETY PRACTICES:

1. Never mix R-410A with other refrigerants.
2. Use gloves and safety glasses, Polyol Ester oils can be irritating to the skin, and liquid refrigerant will freeze the skin.
3. Never use air and R-410A to leak check; the mixture may become flammable.
4. Do not inhale R-410A – the vapor attacks the nervous system, creating dizziness, loss of coordination and slurred speech. Cardiac irregularities, unconsciousness and ultimate death can result from breathing this concentration.
5. Do not burn R-410A. This decomposition produces hazardous vapors. Evacuate the area if exposed.
6. Use only cylinders rated DOT4BA/4BW 400.
7. Never fill cylinders over 80% of total capacity.
8. Store cylinders in a cool area, out of direct sunlight.
9. Never heat cylinders above 125°F.
10. Never trap liquid R-410A in manifold sets, gauge lines or cylinders. R-410A expands significantly at warmer temperatures. Once a cylinder or line is full of liquid, any further rise in temperature will cause it to burst.

## IMPORTANT INSTALLER NOTE

For improved start up performance wash the indoor coil with a dish washing detergent.

## HIGH PRESSURE SWITCH

All J\*\*A/J\*\*L wall mounted air conditioner series models are supplied with a remote reset for the high and low pressure switch. If tripped, this pressure switch may be reset by turning the thermostat off then back on again.

## THREE PHASE SCROLL COMPRESSOR START UP INFORMATION

Scroll compressors, like several other types of compressors, will only compress in one rotational direction. Direction of rotation is not an issue with single phase compressors since they will always start and run in the proper direction.

However, three phase compressors will rotate in either direction depending upon phasing of the power. Since there is a 50-50 chance of connecting power in such a way as to cause rotation in the reverse direction, verification of proper rotation must be made. Verification of proper rotation direction is made by observing that suction pressure drops and discharge pressure rises when the compressor is energized. Reverse rotation also results in an elevated sound level over that with correct rotation, as well as substantially reduced current draw compared to tabulated values.

Verification of **proper rotation** must be made at the time the equipment is put into service. If improper rotation is corrected at this time, there will be no negative impact on the durability of the compressor. However, reverse operation for over one hour may have a negative impact on the bearing due to oil pump out.

*NOTE: If compressor is allowed to run in reverse rotation for an extended period of time, the compressor's internal protector will trip.*

All three phase compressors are wired identically internally. As a result, once the correct phasing is determined for a specific system or installation, connecting properly phased power leads to the same Fusite terminal should maintain proper rotation direction.

The direction of rotation of the compressor may be changed by reversing any two line connections to the unit.

## PHASE MONITOR

All units with three phase scroll compressors are equipped with a 3 phase line monitor to prevent compressor damage due to phase reversal.

The phase monitor in this unit is equipped with two LEDs. If the Y signal is present at the phase monitor and phases are correct the green LED will light.

If phases are reversed, the red fault LED will be lit and compressor operation is inhibited.

If a fault condition occurs, reverse two of the supply leads to the unit. ***Do not reverse any of the unit factory wires as damage may occur.***

## CONDENSER FAN OPERATION

*NOTE: Certain models may be equipped with a low ambient control (LAC), and if so equipped, the condenser fan motor will have delayed start until system refrigerant operating pressure builds up. After starting, the fan motor may or may not cycle depending upon ambient conditions. This is normal operation.*

*Applies to J42, J48, J60 and J70 models only.* The condenser fan motor on 230/208 volt, one and three phase, 60 HZ units is a two-speed motor that comes factory wired on high speed for peak performance. If ambient conditions permit, it can be reconnected to low speed (red wire) for lower sound level. See wiring diagram.

50 HZ models must have fan wired on low speed. These models are factory wired on low speed.

## SERVICE HINTS

1. Caution owner/operator to maintain clean air filters at all times. Also, not to needlessly close off supply and return air registers. This reduces airflow through the system, which shortens equipment service life as well as increasing operating costs.
2. Check all power fuses or circuit breakers to be sure they are the correct rating.
3. Periodic cleaning of the outdoor coil to permit full and unrestricted airflow circulation is essential.

## SEQUENCE OF OPERATION

**COOLING** – Circuit R-Y makes at thermostat pulling in compressor contactor, starting the compressor and outdoor motor. (See **NOTE** under Condenser Fan Operation if equipped with Low Ambient Control.) The G (indoor motor) circuit is automatically completed by the thermostat on any call for cooling operation or can be energized by manual fan switch on subbase for constant air circulation. On a call for heating, circuit R-W1 make at the thermostat pulling in heat contactor for the strip heat and blower operation. On a call for second stage heat, R-W2 makes bringing on second heat contactor, if so equipped.

## COMPRESSOR CONTROL MODULE

The compressor control module is standard on all models covered by this manual. The compressor control module is an anti-short cycle/lockout timer with high and low pressure switch monitoring and alarm relay output.

### Adjustable Delay On Make And Break Timer

On initial power up or anytime power is interrupted to the unit, the *delay on make* period begins, which will be 2 minutes plus 10% of the *delay on break* setting. When the delay on make is complete and the high pressure switch and low pressure switch is closed, the compressor contactor is energized. Upon shutdown, the delay on break timer starts and prevents restart until the delay on break and delay on make periods have expired.

During routine operation of the unit with no power interruptions, the compressor will operate on demand with no delay.

### High Pressure Switch and Lockout Sequence

If the high pressure switch opens, the compressor contactor will de-energize immediately. The lockout timer will go into a *soft lockout* and stay in soft lockout until the high pressure switch closes and the delay on break time has expired. If the high pressure switch opens again in this same operating cycle, the unit will go into *manual lockout* condition and the alarm relay circuit will energize. Recycling the wall thermostat resets the manual lockout.

### Low Pressure Switch, Bypass, and Lockout Sequence

If the low pressure switch opens for more than 120 seconds, the compressor contactor will de-energize and go into a soft lockout. Regardless the state of the low pressure switch, the contactor will reenergize after the delay on make time delay has expired. If the low pressure switch remains open, or opens again for longer than 120 seconds, the unit will go into manual lockout condition and the alarm relay circuit will energize. Recycling the wall thermostat resets the manual lockout.

## Alarm Relay Output

Alarm terminal is output connection for applications where alarm relay is employed. This terminal is powered whenever the compressor is locked out due to HPC or LPC sequences as described.

*NOTE: Both high and low pressure switch controls are inherently automatic reset devices. The high pressure switch and low pressure switch cut out and cut in settings are fixed by specific air conditioner unit model. The lockout features, both soft and manual, are a function of the Compressor Control Module.*

## ADJUSTMENTS

### Adjustable Delay on Make and Delay on Break Timer

The potentiometer is used to select Delay on Break time from 30 seconds to 5 minutes. Delay on Make (DOM) timing on power-up and after power interruptions is equal to 2 minutes plus 10% of Delay on Break (DOB) setting:

0.5 minute (30 seconds)	DOB = 123	second DOM
1.0 minute (60 seconds)	DOB = 126	second DOM
2.0 minute (120 seconds)	DOB = 132	second DOM
3.0 minute (180 seconds)	DOB = 138	second DOM
4.0 minute (240 seconds)	DOB = 144	second DOM
5.0 minute (300 seconds)	DOB = 150	second DOM

During routine operation of the unit with no power interruptions the compressor will operate on demand with no delay.

### Typical Settings for Dual Unit Installation:

Unit 1: DOB set at 2 minutes, and DOM is 132 seconds

Unit 2: DOB set at 4 minutes, and DOM is 144 seconds

## PRESSURE SERVICE PORTS

High and low pressure service ports are installed on all units so that the system operating pressures can be observed. A pressure table can be found later in the manual covering all models. It is imperative to match the correct pressure table to the unit by model number. See Table 4.

# TROUBLESHOOTING

## FAN BLADE SETTING DIMENSIONS

Shown in Figure 11 is the correct fan blade setting for proper air delivery across the outdoor coil. Refer to Table 1 for unit specific dimension.

Any service work requiring removal or adjustment in the fan and/or motor area will require that the dimensions below be checked and blade adjusted in or out on the motor shaft accordingly.

**FIGURE 11  
FAN BLADE SETTING**

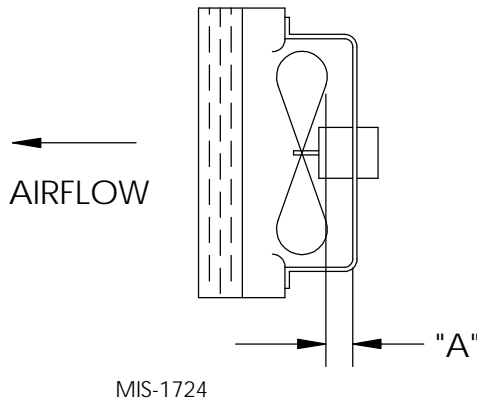

**TABLE 1  
FAN BLADE DIMENSION**

Model	Dimension A
J17A2 / J17L2 J24A2 / J24L2	1.00"
J30A2 / J30L2 J36A2 / J36L2	1.25"
J42A2 / J42L2 J48A2 / J48L2 J60A2 / J60L2 J70A2 / J70L2	1.75"

## REMOVAL OF FAN SHROUD

1. Disconnect all power to the unit.
2. Remove the screws holding both grilles, one on each side of unit, and remove grilles.
3. Remove screws holding fan shroud to condenser and bottom. Nine (9) screws.
4. Unwire condenser fan motor.
5. Slide complete motor, fan blade, and shroud assembly out the left side of the unit.
6. Service motor/fan as needed.
7. Reverse steps to reinstall.

## R-410A

### REFRIGERANT CHARGE

This unit was charged at the factory with the quantity of refrigerant listed on the serial plate. AHRI capacity and efficiency ratings were determined by testing with this refrigerant charge quantity.

The following pressure tables show nominal pressures for the units. Since many installation specific situations can affect the pressure readings, this information should only be used by certified technicians as a guide for evaluating proper system performance. They shall not be used to adjust charge. If charge is in doubt, reclaim, evacuate and recharge the unit to the serial plate charge.

**TABLE 2  
REFRIGERANT CHARGE**

Model	Rated Airflow	95°F OD Temperature	82°F OD Temperature
J24A2 / J24L2	800	56 - 60	56 - 60
J30A2 / J30L2	1000	57 - 61	57 - 61
J36A2 / J36L2	1100	56 - 60	57 - 61
J42A2 / J42L2	1400	58 - 62	60 - 64
J48A2 / J48L2	1550	63 - 67	65 - 69
J60A2 / J60L2	1650	63 - 67	64 - 68

The suction line temperatures in Table 4 above are based upon 80°F dry bulb / 67°F wet bulb (50% R.H.) temperature and rated airflow across the evaporator during cooling cycle.

**TABLE 3  
REFRIGERANT CHARGE**

Model	Rated Airflow	95°F OD Temperature	82°F OD Temperature
J17A1 / J17L1	550	18 - 21°	19 - 22°
J70A1 / J70L1	1800	15 - 18°	16 - 19°

The correct system R-410A charge is shown on the unit nameplate. Optimum unit performance will occur with a refrigerant charge resulting in a liquid subcooling as shown in Tables 2 & 3. If charge is in doubt, reclaim and recharge to factory nameplate charge.

**TABLE 4  
COOLING PRESSURE TABLE**

Air Temperature Entering Outdoor Coil °F

Model	Return Air Temp (DB/WB)	Pressure	75	80	85	90	95	100	105	110	115	120
J17A/L	75/62	Low Side	124	126	128	130	132	133	135	137	138	140
		High Side	321	340	362	384	409	434	461	490	521	553
	80/67	Low Side	133	135	137	139	141	142	144	146	148	150
		High Side	329	349	371	394	419	445	473	503	534	567
	85/72	Low Side	138	140	142	144	146	147	149	151	153	155
		High Side	341	361	384	408	434	461	490	521	553	587
J24A/L	75/62	Low Side	119	121	122	124	127	129	131	133	135	137
		High Side	340	361	383	407	432	459	488	518	550	583
	80/67	Low Side	127	129	131	133	136	138	140	142	144	146
		High Side	349	370	393	417	443	471	500	531	564	598
	85/72	Low Side	131	134	136	138	141	143	145	147	149	151
		High Side	361	383	407	432	459	487	518	550	584	619
J30A/L	75/62	Low Side	122	124	127	129	131	133	135	137	137	139
		High Side	335	358	381	406	431	456	483	509	536	565
	80/67	Low Side	130	133	136	138	140	142	144	146	147	149
		High Side	344	367	391	416	442	468	495	522	550	579
	85/72	Low Side	135	138	141	143	145	147	149	151	152	154
		High Side	356	380	405	431	457	484	512	540	569	599
J36A/L	75/62	Low Side	120	122	124	126	129	130	132	134	135	136
		High Side	339	366	392	418	446	473	501	529	558	586
	80/67	Low Side	128	130	133	135	138	139	141	143	144	145
		High Side	348	375	402	429	457	485	514	543	572	601
	85/72	Low Side	132	135	138	140	143	144	146	148	149	150
		High Side	360	388	416	444	473	502	532	562	592	622
J42A/L	75/62	Low Side	123	124	126	128	130	132	134	136	137	139
		High Side	320	342	367	391	416	443	469	496	526	554
	80/67	Low Side	132	133	135	137	139	141	143	145	147	149
		High Side	328	351	376	401	427	454	481	509	539	568
	85/72	Low Side	137	138	140	142	144	146	148	150	152	154
		High Side	339	363	389	415	442	470	498	527	558	588
J48A/L	75/62	Low Side	117	119	121	123	125	127	129	131	133	135
		High Side	355	378	403	427	454	482	510	539	570	603
	80/67	Low Side	125	127	129	132	134	136	138	140	142	144
		High Side	364	388	413	438	466	494	523	553	585	618
	85/72	Low Side	129	131	134	137	139	141	143	145	147	149
		High Side	377	402	427	453	482	511	541	572	605	640
J60A/L	75/62	Low Side	122	124	126	128	130	131	133	135	137	138
		High Side	346	371	396	421	447	473	499	526	553	580
	80/67	Low Side	131	133	135	137	139	140	142	144	146	148
		High Side	355	380	406	432	458	485	512	539	567	595
	85/72	Low Side	136	138	140	142	144	145	147	149	151	153
		High Side	367	393	420	447	474	502	530	558	587	616
J70A/L	75/62	Low Side	118	121	122	123	125	127	129	131	132	134
		High Side	349	371	395	419	444	470	497	525	553	583
	80/67	Low Side	126	129	131	132	134	136	138	140	141	143
		High Side	358	381	405	430	455	482	510	538	567	598
	85/72	Low Side	130	134	136	137	139	141	143	145	146	148
		High Side	371	394	419	445	471	499	528	557	587	619

Low side pressure ± 4 PSIG  
High side pressure ± 10 PSIG

Tables are based upon rated CFM (airflow) across the evaporator coil. If there is any doubt as to correct operating charge being in the system, the charge should be removed, system evacuated and recharged to serial plate charge weight.

**NOTE:** Pressure table based on high speed condenser fan operation. If condensing pressures appear elevated check condenser fan wiring. See "Condenser Fan Operation".

TABLE 5

Electrical Specifications — J**A Series														
MODEL	Rated Volts & Phase	No. Field Power Circuits	Single Circuit				Dual Circuit							
			③ Minimum Circuit Ampacity	① Maximum External Fuse or Ckt. Brkr.	② Field Power Wire Size	② Ground Wire	③ Minimum Circuit Ampacity		① Maximum External Fuse or Ckt. Breaker		② Field Power Wire Size		② Ground Wire Size	
							Ckt. A	Ckt. B	Ckt. A	Ckt. B	Ckt. A	Ckt. B	Ckt. A	Ckt. B
J17A2-A00, A0Z A05 A08 A10	230/208-1	1	16	20	12	12								
		1	30	30	10	10								
		1	46	50	8	10								
		1	56	60	6	10								
J24A2-A00, A0Z A04 A05 A08 A10	230/208-1	1	21	30	10	10								
		1	25	30	10	10								
		1	30	30	10	10								
		1	46	50	8	10								
J24A2-B00, B0Z B06	230/208-3	1	15	20	12	12								
		1	22	25	10	10								
		1	9	15	14	14								
		1	11	15	14	14								
J24A2-C00, C0Z C06	460-3	1	9	15	14	14								
		1	11	15	14	14								
		1	24	35	8	10								
		1	32	35	8	10								
J30A2-A00*, A0Z* A05* A08 A10* A15	230/208-1	1	47	50	8	10								
		1	58	60	6	10								
		1 or 2	84	90	4	8	58	26	60	30	6	10	10	10
		1	18	20	12	12								
J30A2-B00*, B0Z* B06 B09* B15	230/208-3	1	24	25	10	10								
		1	33	35	8	10								
		1	51	60	6	10								
		1	11	15	14	14								
J30A2-C00*, C0Z* C06 C09* C15	460-3	1	12	15	14	14								
		1	17	20	12	12								
		1	26	30	10	10								
		1	29	35	8	10								
J36A2-A00*, A0Z* A05* A08 A10* A15	230/208-1	1	32	35	8	10								
		1	47	50	8	10								
		1	58	60	6	10								
		1 or 2	84	90	4	8	58	26	60	30	6	10	10	10
J36A2-B00*, B0Z* B06* B09* B15	230/208-3	1	23	30	10	10								
		1	24	30	10	10								
		1	33	35	8	10								
		1	51	60	6	10								
J36A2-C00*, C0Z* C06* C09* C15	460-3	1	11	15	14	14								
		1	12	15	14	14								
		1	16	20	12	12								
		1	26	30	10	10								
J42A2-A00, A0Z A05 A10 A15 A20	230/208-1	1	32	50	8	10								
		1	32	50	8	10								
		1	58	60	6	10								
		1 or 2	84	90	4	8	58	26	60	30	6	10	10	10
J42A2-B00, B0Z B09 B15 B18	230/208-3	1	24	35	8	10								
		1	33	35	8	10								
		1	51	60	6	10								
		1	60	60	6	10								
J42A2-C00, C0Z C09 C15	460-3	1	12	15	14	14								
		1	17	20	12	12								
		1	26	30	10	10								
		1	39	50	8	10								
J48A2-A00, A0Z A05 A10 A15 A20	230/208-1	1	39	50	8	10								
		1	39	50	8	10								
		1	58	60	6	10								
		1 or 2	84	90	4	8	58	26	60	30	6	10	10	10
J48A2-B00, B0Z B09 B15 B18	230/208-3	1	27	40	8	10								
		1	33	40	8	10								
		1	51	60	6	10								
		1	60	60	6	10								
J48A2-C00, C0Z C09 C15	460-3	1	13	20	12	12								
		1	17	20	12	12								
		1	26	30	10	10								
		1	42	60	8	10								
J60A2-A00, A0Z A05 A10 A15 A20	230/208-1	1	42	60	8	10								
		1	42	60	8	10								
		1	60	60	6	10								
		1 or 2	86	90	3	8	60	26	60	30	6	10	10	10
J60A2-B00, B0Z B09 B15 B18	230/208-3	1	28	40	8	10								
		1	35	40	8	10								
		1	53	60	6	10								
		2	N/A	N/A	N/A	N/A	35	28	40	30	8	10	10	10
J60A2-C00, C0Z C09 C15	460-3	1	15	20	12	12								
		1	18	20	12	12								
		1	27	30	10	10								
		1	56	60	6	10								
J70A2-A00, A0Z A05 A10 A15 A20	230/208-1	1	56	60	6	10								
		1	56	60	6	10								
		1	59	60	6	10								
		1 or 2	85	90	4	8	59	26	60	30	6	10	10	10
J70A2-B00, B0Z B09 B15 B18	230/208-3	1	38	60	8	10								
		1	38	60	8	10								
		1	53	60	6	10								
		2	N/A	N/A	N/A	N/A	38	28	60	30	8	10	10	10
J70A2-C00, C0Z C09 C15	460-3	1	19	30	10	10								
		1	19	30	10	10								
		1	27	35	18	10								

- ① Maximum size of the time delay fuse or HACR type circuit breaker for protection of field wiring conductors.
- ② Based on 75C copper wire. All wiring must conform to the National Electrical Code and all local codes.
- ③ These "Minimum Circuit Ampacity" values are to be used for sizing the field power conductors. Refer to the National Electrical code (latest version), Article 310 for power conductor sizing.

**Caution:** When more than one field power circuit is run through one conduit, the conductors must be derated. Pay special attention to note 8 of Table 310 regarding Ampacity Adjustment Factors when more than three (3) current carrying conductors are in a raceway.

\* Top outlet supply option is available only factory installed and only on the selected models.

**IMPORTANT:** While this electrical data is presented as a guide, it is important to electrically connect properly sized fuses and conductor wires in accordance with the National Electrical Code and all local codes.

TABLE 6

Electrical Specifications — J**L Series														
MODEL	Rated Volts & Phase	No. Field Power Circuits	Single Circuit				Dual Circuit							
			③ Minimum Circuit Ampacity	① Maximum External Fuse or Ckt. Brkr.	② Field Power Wire Size	② Ground Wire	③ Minimum Circuit Ampacity		① Maximum External Fuse or Ckt. Breaker		② Field Power Wire Size		② Ground Wire Size	
							Ckt. A	Ckt. B	Ckt. A	Ckt. B	Ckt. A	Ckt. B	Ckt. A	Ckt. B
J17L2-A00, A0Z A05 A08 A10	230/208-1	1	16	20	12	12								
		1	30	30	10	10								
		1	46	50	8	10								
		1	56	60	6	10								
J24L2-A00, A0Z A05 A08 A10	230/208-1	1	21	30	10	10								
		1	30	30	10	10								
		1	46	50	8	10								
		1	56	60	6	10								
J24L2-B00, B0Z B06	230/208-3	1	15	20	12	12								
		1	22	25	10	10								
J24L2-C00, C0Z C06	460-3	1	9	15	14	14								
		1	11	15	14	14								
J30L2-A00*, A0Z* A05* A08 A10* A15	230/208-1	1	24	35	8	10								
		1	32	35	8	10								
		1	47	50	8	10								
		1	58	60	6	10								
		1 or 2	84	90	4	8	58	26	60	30	6	10	10	10
J30L2-B00*, B0Z* B09* B15	230/208-3	1	18	20	12	12								
		1	33	35	8	10								
		1	51	60	6	10								
J30L2-C00*, C0Z* C09* C15	460-3	1	11	15	14	14								
		1	17	20	12	12								
		1	26	30	10	10								
J36L2-A00*, A0Z* A05* A10* A15	230/208-1	1	29	35	8	10								
		1	32	35	8	10								
		1	58	60	6	10								
		1 or 2	84	90	4	8	58	26	60	30	6	10	10	10
		1	23	30	10	10								
J36L2-B00*, B0Z* B09* B15	230/208-3	1	33	35	8	10								
		1	51	60	6	10								
		1	11	15	14	14								
J36L2-C00*, C0Z* C09* C15	460-3	1	16	20	12	12								
		1	26	30	10	10								
		1	32	50	8	10								
J42L2-A00, A0Z A05 A10 A15	230/208-1	1	32	50	8	10								
		1	32	50	8	10								
		1	58	60	6	10								
		1 or 2	84	90	4	8	58	26	60	30	6	10	10	10
J42L2-B00, B0Z B09 B15	230/208-3	1	24	35	8	10								
		1	33	35	8	10								
		1	51	60	6	10								
J42L2-C00, C0Z C09 C15	460-3	1	12	15	14	14								
		1	17	20	12	12								
		1	26	30	10	10								
J48L2-A00, A0Z A05 A10 A15	230/208-1	1	39	50	8	10								
		1	39	50	8	10								
		1	58	60	6	10								
		1 or 2	84	90	4	8	58	26	60	30	6	10	10	10
		1	27	40	8	10								
J48L2-B00, B0Z B09 B15	230/208-3	1	33	40	8	10								
		1	51	60	6	10								
		1	13	20	12	12								
J48L2-C00, C0Z C09 C15	460-3	1	17	20	12	12								
		1	26	30	10	10								
		1	42	60	8	10								
J60L2-A00, A0Z A05 A10 A15	230/208-1	1	42	60	8	10								
		1	42	60	8	10								
		1	60	60	6	10								
		1 or 2	86	90	3	8	60	26	60	30	6	10	10	10
J60L2-B00, B0Z B09 B15	230/208-3	1	28	40	8	10								
		1	35	40	8	10								
		1	53	60	6	10								
J60L2-C00, C0Z C09 C15	460-3	1	15	20	12	12								
		1	18	20	12	12								
		1	27	30	10	10								
J70L2-A0Z A05 A10 A15	230/208-1	1	56	60	6	10								
		1	56	60	6	10								
		1	59	60	6	10								
		1 or 2	85	90	4	8	59	26	60	30	6	10	10	10
		1	38	60	8	10								
J70L2-B0Z B09 B15	230/208-3	1	38	60	8	10								
		1	53	60	6	10								
		1	19	30	10	10								
J70L2-C0Z C09 C15	460-3	1	19	30	10	10								
		1	19	30	10	10								
		1	27	35	18	10								

- ① Maximum size of the time delay fuse or HACR type circuit breaker for protection of field wiring conductors.
- ② Based on 75C copper wire. All wiring must conform to the National Electrical Code and all local codes.
- ③ These "Minimum Circuit Ampacity" values are to be used for sizing the field power conductors. Refer to the National Electrical code (latest version), Article 310 for power conductor sizing.

**Caution:** When more than one field power circuit is run through one conduit, the conductors must be derated. Pay special attention to note 8 of Table 310 regarding Ampacity Adjustment Factors when more than three (3) current carrying conductors are in a raceway.

\* Top outlet supply option is available only factory installed and only on the selected models.

**IMPORTANT:** While this electrical data is presented as a guide, it is important to electrically connect properly sized fuses and conductor wires in accordance with the National Electrical Code and all local codes.



**TABLE 7  
RECOMMENDED AIRFLOW**

Model	Nominal Rated CFM *	Nominal Rated ESP *	Recommended Airflow Range	Factory Speed Connection
J17A, J17L	600	.40	550 - 725	Low
J24A, J24L	800	.30	700 - 950	Single
J30A, J30L	1000	.30	850 - 1300	High
J36A, J36L	1100	.20	930 - 1350	High
J42A, J42L	1400	.45	1600 - 1150	High
J48A, J48L	1550	.30	1750 - 1285	High
J60A, J60L	1700	.40	1950 - 1375	High
J70A, J70L	1700	.20	1950 - 1375	High

\* Rated CFM and ESP on factory speed connection.

**TABLE 8  
INDOOR BLOWER PERFORMANCE**

Speed	J17				J24		J30				J36				J42/48				J60				J70			
	High		Low		Single		High		Low		High		Low		High		Low		High		Low		High		Low	
ESP (Inch H2O)	Dry Coil	Wet Coil	Dry Coil	Wet Coil	Dry Coil	Wet Coil	Dry Coil	Wet Coil	Dry Coil	Wet Coil	Dry Coil	Wet Coil	Dry Coil	Wet Coil	Dry Coil	Wet Coil	Dry Coil	Wet Coil	Dry Coil	Wet Coil	Dry Coil	Wet Coil	Dry Coil	Wet Coil	Dry Coil	Wet Coil
0.0	1045	1025	760	745	990	970	1370	1285	910	885	1415	1275	955	925	1850	1800	1605	1555	2080	2015	1505	1460	2050	1845	1490	1400
0.1	1010	970	730	715	945	925	1305	1225	885	860	1350	1215	945	915	1775	1725	1545	1500	2020	1960	1450	1405	1970	1770	1425	1340
0.2	940	905	700	685	890	870	1225	1135	850	815	1265	1125	925	900	1685	1640	1460	1415	1925	1865	1395	1355	1905	1700	1375	1295
0.3	860	830	670	655	820	800	1115	1020	790	755	1190	1060	875	850	1590	1550	1390	1345	1870	1815	1340	1300	1830	1645	1225	1150
0.4	780	750	610	595	735	720	1005	910	695	660	1085	975	780	755	1495	1460	1310	1270	1755	1705	1225	1185	1725	1550	1140	1070
0.5	665	640	485	455	605	590	865	775	590	560	970	865	640	615	1400	1365	1225	1185	1660	1610	1125	1085	1500	1350	1050	985

**TABLE 9  
MAXIMUM ESP OF OPERATION  
ELECTRIC HEAT ONLY**

Model	J17A/L, J24A/L	J30A/L, J36A/L				J42A/L, J48A/L		J60A/L, J70A/L	
Outlet	FRONT	FRONT		TOP		FRONT		FRONT	
Speed	Single	High	Low	High	Low	High	Low	High	Low
-A0Z	.50	.50	.50	.50	.50	.50	.50	.50	.50
-A04				.50	.45				
-A05	.50	.50	.50			.50	.50	.50	.50
-A08	.50	.50	.50						
-A10		.50	.45	.50	.35	.50	.50	.50	.50
-A15		.40	.35			.50	.50	.50	.50
-A20						.50	.45	.50	.40
-B0Z	.50	.50	.50	.50	.50	.50	.50	.50	.50
-B06	.50	.50	.40						
-B09		.50	.50	.45	.40	.50	.50	.50	.50
-B15		.45	.30			.50	.50	.50	.50
-B18						.50	.50	.50	.50
-C0Z		.50	.50	.50	.50	.50	.50	.50	.50
-C06		.50	.50						
-C09		.50	.40	.45	.40	.50	.50	.50	.50
-C15		.45	.35			.50	.50	.50	.50

Values shown are for units equipped with standard 1-inch throwaway filter or 1-inch washable filter. Derate ESP by .15 for 2-inch pleated filters.

**TABLE 10  
ELECTRIC HEAT**

Models	240V-1		208V-1		240V-3		208V-3		460V-3		
	KW	Amps	BTUH	Amps	BTUH	Amps	BTUH	Amps	BTUH	Amps	BTUH
4	16.7	13650	14.4	10240							
5	20.8	17065	18.1	12800							
6					14.4	20500	12.5	15360	7.2	20500	
8	33.3	27300	28.8	20475							
9					21.7	30600	18.7	23030	10.8	30700	
10	41.6	34130	36.2	25600							
12									14.4	40950	
15	62.5	51250	54.0	38400	36.2	51200	31.2	38400	18.0	51200	
18					43.3	61430	37.5	46100			
20	83.2	68260	72.1	51200							

**TABLE 11A  
OPTIONAL ACCESSORIES — RIGHT HAND**

	J17A2-A	J24A2-A	J24A2-B	J24A2-C	J30A2-A	J30A2-B	J30A2-C	J36A2-A	J36A2-B	J36A2-C	J42A2-A	J42A2-B	J42A2-C	J48A2-A	J48A2-B	J48A2-C	J60A2-A	J60A2-B	J60A2-C	J70A2-A	J70A2-B	J70A2-C	
<b>HEATER KITS</b>	EHWA02-A05	X	X																				
	EHW02A-A08	X	X																				
	EHWA02A-A10	X	X																				
	EHWA24-A04		X																				
	EHWA24-B06			X																			
	EHWH24B-C06				X																		
	EHWA03-A05					X			X														
	EHWA03-A08					X			X														
	EHWA03-A10					X			X														
	EHWA03-A15					X			X														
	EHWA03-B06						X																
	EHW36A-B06									X													
	EHWA03-B09						X			X													
	EHWA37-B15						X			X													
	EHWC03A-C06							X			X												
	EHWC03A-C09							X			X												
	EHWA03A-C12							X			X												
	EHWA03A-C15							X			X												
	EHWA05-A05											X			X								
	EHWA05-A10											X			X			X			X		
	EHWA05-A15											X			X			X			X		
	EHWA05-A20											X			X			X			X		
	EHWA05-B09												X			X							
	EHWA05-B15												X			X			X			X	
	EHW05A-B18																		X				
	EHWA05-B18												X			X							
	EHWA05A-C09													X			X			X			X
	EHWA05A-C15												X				X			X			X
	EHWA60-A05																	X			X		
	EHW60A-B09																		X				
EHW70A-B09																					X		
EHW70A-B18																					X		
<b>CIRCUIT BREAKER (WMCB) &amp; PULL DISCONNECT (WMPD)</b>	WMCB-01B			X																			
	WMCB-02A	X																					
	WMCB-02B					X																	
	WMCB-03A		X																				
	WMCB-04B								X														
	WMCB-05A				X			X															
	WMCB-05B										X				X								
	WMCB-06B																X						
	WMCB-08A										X				X								
	WMCB-09A																X			X			
WMPD-01C			X			X			X			X			X			X			X		
WMCB-08B																					X		

**TABLE 11B  
OPTIONAL ACCESSORIES — LEFT HAND**

		J17L2-A	J24L2-A	J24L2-B	J30L2-A	J30L2-B	J30L2-C	J36L2-A	J36L2-B	J36L2-C	J42L2-A	J42L2-B	J42L2-C	J48L2-A	J48L2-B	J48L2-C	J60L2-A	J60L2-B	J60L2-C	J70L2-A	J70L2-B	J70L2-C	
<b>HEATER KITS</b>	EHWA02A-A05L	X	X																				
	EHW02A-A08L	X	X																				
	EHWA02-A10L	X	X																				
	EHWA24-B06L			X																			
	EHWA03-A05L				X			X															
	EHWA03-A08L				X																		
	EHWA03-A10L				X			X															
	EHWA03-A15L				X			X															
	EHWA03-B09L					X			X														
	EHWA37-B15L					X			X														
	EHWC03-C09L						X			X													
	EHWA03-C15L						X			X													
	EHWA05-A05L										X			X			X						
	EHWA05-A10L										X			X			X			X			
	EHWA05-A15L										X			X			X			X			
	EHWA05-B09L											X			X								
	EHWA05-B15L											X			X			X				X	
	EHWA05A-C09L												X			X			X				X
	EHWA05A-C15L												X			X			X				X
	EHWA60-A05L																				X		
EHWA60-B09L																		X					
EHW70A-B09L																					X		
<b>CIRCUIT BREAKER (WMCB) &amp; PULL DISCONNECT (WMPD)</b>	WMCB-01B			X																			
	WMCB-02A	X																					
	WMCB-02B					X																	
	WMCB-03A		X																				
	WMCB-04B								X														
	WMCB-05A				X			X															
	WMCB-05B										X				X								
	WMCB-06B																	X					
	WMCB-08A										X			X									
	WMCB-09A																X			X			
	WMPD-01C						X			X			X			X			X				X
	WMCB-09B																					X	

**TABLE 12  
VENT & CONTROL OPTIONS**

<b>Part Number</b>	<b>Description</b>	<b>J17, J24</b>	<b>W30, J36</b>	<b>J42, J48, J60, J70</b>
BFAD-2	Barometric Fresh Air Damper - Standard	X		
ECONWMS-E2	Economizer - School Version, Enthalpy	X		
ECONWMT-E2	Economizer - Bldg. Equipment, Enthalpy	X		
ECONWMT-T2	Economizer - Bldg. Equipment, DB Temp.	X		
BFAD-3	Barometric Fresh Air Damper - Standard		X	
ECONWMS-E3	Economizer - School Version, Enthalpy		X	
ECONWMT-E3	Economizer - Bldg. Equipment, Enthalpy		X	
ECONWMT-T3	Economizer - Bldg. Equipment, DB Temp.		X	
BFAD-5	Barometric Fresh Air Damper - Standard			X
ECONWMS-E5	Economizer - School Version, Enthalpy			X
ECONWMT-E5	Economizer - Bldg. Equipment, Enthalpy			X
ECONWMT-T5	Economizer - Bldg. Equipment, DB Temp.			X