



GT Series High Efficiency Geothermal/Water Source Step-Capacity Heat Pump — R-410A

Ground Water Application: Water Temp 45° to 75°

Ground Loop Application: Temp Range 25° to 110°

The GT Series Geothermal/Water Source Heat Pump delivers economical year-round comfort by utilizing nature's most abundant and efficient solar energy collector – the earth. The GT Series heat pumps are designed for low water flow rates and offer cooling efficiencies up to 29.1 EER and heating efficiencies up to 4.8 COP on ground water, and cooling efficiencies up to 24.9 EER and heating efficiencies up to 4.4 COP on ground loop.

All units are shipped prewired for fast, easy installation in residential or commercial buildings.

TYPICAL INSTALLATION APPLICATIONS

Compressor, Blower and A Coil Sections stack vertically for upflow and counterflow installations. Blower and A Coil Sections can be remotely mounted in attics or crawl spaces providing horizontal right or left opportunities.



Engineered Features

Steel Cabinet:

Galvanized 20 gauge zinc coated steel cabinet with baked-on, textured enamel which allows it to withstand 1000 hours of salt spray exposure.

Multi-Capacity Two-Stage:

Simple thermostatic control seamlessly stages the compressor and indoor airflow rate between full and part load capacity operation without cycling the compressor. This helps to maximize comfort, humidity control, energy efficiency and overall reduction in compressor cycling for improved system life.

Step Capacity Compressor:

Copeland step-capacity (2-stage) scroll compressors are designed for increased efficiency, quieter operation and improved reliability for longer life.

R-410A Refrigerant:

Designed with R-410A (HFC) non-ozone depleting refrigerant in compliance with the Montreal protocol and 2010 EPA requirements.

Liquid Line Drier:

Protects system against moisture.

Thermostatic Expansion Valve:

For wide range refrigerant control (2-way operation).

High Pressure Switch:

Provides additional protection for the system.

Low Pressure Switch:

Two switches provided. Factory wired switch is for ground water applications, alternate switch is field connected for ground loop applications.

Control Panel:

Mid-level for easy access. Blower section includes transformer and blower control.

High Efficiency Coaxial Water Coil in either Copper or Cupronickel

Water to refrigerant coil is completely insulated to prevent frost build-up at low temperature operation.

Indoor Air Coil:

Grooved copper tubing and enhanced louvered aluminum fin for maximum heat transfer and energy efficiency.

Coil is constructed with special corrosion resistant hydrophilic fin stock with 2-layer coating. (1st layer - blue acrylic primer; 2nd layer - clear topcoat.)

Alternate coil coating is black E-Coat electrostatic coating on complete coil.

Lockout Circuit:

Built-in lockout circuit resets from the room thermostat. Provides commercial quality protection to the compressor.

Variable Speed ECM Blower Motor:

- High Efficiency
- Soft starting - low noise on start up
- Continuous fan - will operate at 50% of rated Stage 2 airflow

Mild Weather Operation:

Part Load Cooling Operation will operate at 20% reduced airflow for the first 5 minutes of operation. This results in 32% increased applied moisture removal during this 5-minute period, and helps humidity control during short-run conditions. This is seamlessly controlled internal of the unit controls with no required user intervention.

Water Connections:

All water connections on outside of cabinet. Brass full swivel double o-ring connection with 1" full flow ports.

Refrigerant Connections:

Special self-sealing fittings are used with 3' line set for stacked upflow or downflow applications, and line sets up to 50' available for horizontal or dual-fuel applications.

Service Access Ports:

Permits service pressure check of discharge and suction pressures.

Filter Rack (Optional):

Accessory kit with 1" filter (reversible for left or right side access for upflow installations).

Accessory Electric Duct Heater Option:

5, 10, 15 and 20KW nominal size. Field installed external to unit. For upflow and horizontal duct installation only.

Optional Accessories:

Room thermostat - Water accessory kit - Waterflow controls.

Domestic Hot Water Heat Exchanger System:

Double wall vented heat exchanger and pump with ECM motor and operating controls, factory installed on all 1-phase models.

Hot Water Heating Performance and

Operating Cost Savings: The actual amount of hot water (gallons of hot water per day) generated and resultant operating cost savings can vary greatly because of several factors: heat pump system size, hours per day of operation of the heat pump, mode of operation (cooling vs. heating), hot water usage patterns, heat pump water supply system (ground water, ground or pond loop, etc.), and climatic conditions. The gallons of hot water per day are dependent upon the above variables, and in general can range up to 125 gallons per day for a nominal 24,000 BTU heat pump system, and up to 375 gallons per day for a nominal 60,000 BTU heat pump system in the cooling mode, offering a 100% energy savings over conventional electric water heaters. During the winter months when the heat pump is operating in the heating mode, less hot water is available, but at the same time, the electric water heater will consume less electricity.

GT Series Geothermal / Water Source Heat Pump Nomenclature

"A" Coil Section



Blower Section

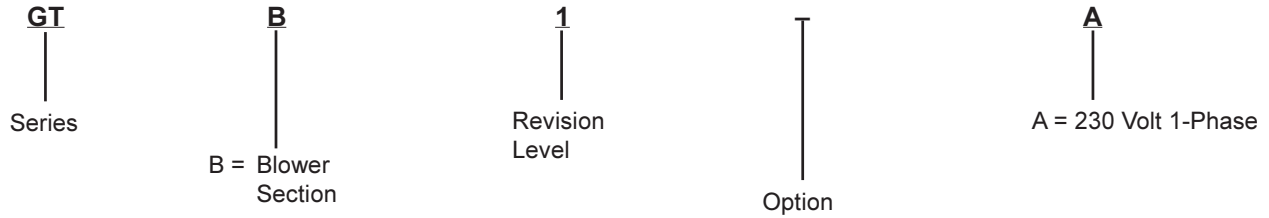

Compressor Section

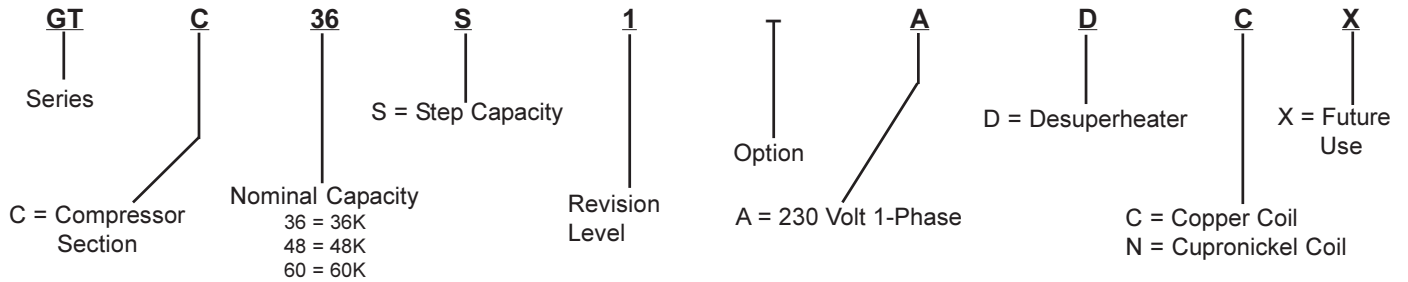

Specifications (Coil, Compressor & Blower Sections Stacked Together)

MODEL	GTC36S1	GTC48S1	GTC60S1
Electrical Rating (60HZ/1PH)	230/208-60-1		
Operating Voltage Range	253-197 VAC		
Minimum Circuit Ampacity	26.0	34.0	38.0
+Field Wire Size	#8	#6	#4
Ground Wire Size	#10	#8	#6
++Delay Fuse or Circuit Breaker Max.	40	50	60
COMPRESSOR			
Volts	230/208-60-1		
Rated Load Amps (230/208)	11.2 / 13.0	16.4 / 19.6	19.2 / 23.6
Branch Circuit Selection Current	16.7	21.2	25.6
Locked Rotor Amps (230/208)	82 / 82	96 / 96	118 / 118
BLOWER MOTOR			
Horsepower (ECM Motor)	3/4 Variable Speed		
Volts	230/208-60-1		
Motor Amps (Stage #2 @ Rated CFM)	3.4	4.3	4.4
FLOW CENTER (Based on DORFC-2)			
Volts	230/208-60-1		
Amps	2.14	2.14	2.14
DESUPERHEATER PUMP MOTOR			
Volts	230/208-60-1		
Amps	0.15	0.15	0.15

Specifications (for Blower Section Only when Remote Mounted from Compressor)

BLOWER SECTION (If Remotely Mounted)	
Model	GTB1-A
HP/Type	3/4 Variable Speed
Motor Amps (RLA)	6.1
Minimum Circuit Ampacity	8
+Field Wire Size	14
++Delay Fuse Max. or Circuit Breaker	15

NOTE: This applies only if blower section is remote mounted from compressor section. When blower section is coupled directly to compressor section, the blower is powered from the compressor section.

+75°C copper wire ++ HACR type circuit breaker

Indoor Blower Performance (Rated CFM) ①

MODEL	② Rated ESP	③ MAX ESP	④ Continuous Airflow	⑤ Mild Climate Operation in Part Load Cooling	⑥ Part Load Airflow	Full Load Airflow	⑦ Electric Heat Airflow
GTC36S1	0.15	0.60	600	700	850	1200	1300
GTC48S1	0.20	0.60	750	875	1150	1500	1600
GTC60S1	0.20	0.60	900	1050	1300	1800	1800

- ① Motor will automatically step through the various airflows with thermostatic control
- ② ESP = External Static Pressure (inches of water)
- ③ Maximum allowable duct static
- ④ Continuous airflow is the CFM being circulated with manual fan operation without any additional function occurring.
- ⑤ Will occur automatically for first 5 minutes of Part Load Cooling Operation.
- ⑥ Will occur automatically after five minutes of Part Load Cooling Operation.
- ⑦ Will occur automatically with control signal input.

NOTE: All values can be changed $\pm 10\%$ via the \pm adjustment dip switches on the tap select control inclusive in the GTB1-A Blower Section (see Airflow Corrections for performance impact).

Airflow Corrections

% of Rated Airflow	Total Capacity (MBtuH)	Sensible Capacity (MBtuH)	Power Input (KW)	Heat of Rejection (MBtuH)	Total Capacity (MBtuH)	Power Input (KW)	Heat of Absorption (MBtuH)
90%	0.985	0.844	0.978	0.983	0.988	1.030	0.978
RATED	1.000	1.000	1.000	1.000	1.000	1.000	1.000
110%	1.010	1.050	1.025	1.013	1.010	0.988	1.015

Shipping Weights

"A" Coil Section	GTA360UD1-A	93 lbs.
	GTA486UD1-A	102 lbs.
"B" Blower Section	GTB1-A	95 lbs.
"C" Compressor Section	GTC36S1	248 lbs.
	GTC48S1	260 lbs.
	GTC60S1	293 lbs.

Correction Factors @ Increased Water Flows

Rated Flow Plus	Cooling		Heating	
	BtuH	Watts	BtuH	Watts
2 GPM	1.005	0.988	1.006	1.002
3 GPM	1.007	0.984	1.009	1.003
4 GPM	1.008	0.979	1.011	1.003

Loop Pump Modules and Pump Outputs for Ground Loop Installations ①

Pump Models	No. of Pumps	WATER FLOW RATE REQUIRED IN GPM				
		7	9	12	15	16
DORFC-1	1	28.5	27.5	25	22.5	22
DORFC-2	2	57	55	50	45	44

① Pump output (feet of head) @ GPM at top of column.

Antifreeze Percentages by Volume for Ground Loop Installations ①

Type	Minimum Temperature for Freeze Protection			
	10°F (-12.2°C)	15°F (-9.4°C)	20°F (-6.7°C)	25°F (-3.9°C)
Methanol	25%	21%	16%	10%
Ethanol ②	29%	25%	20%	14%
100% USP Food Grade Propylene Glycol	27%	24%	20%	13%

① Loop antifreeze protection must be determined based on loop design and geographic location.

② Must not be denatured with any petroleum based product.

Ratings Based on Approved Compressor, A-Coil & Blower Combinations

MODEL	System Capacity Modulation	Fluid Flow Rate GPM	Airflow CFM	Ground Loop Heat Pump — Tested & Certified to ISO 13256-1:1998			
				Cooling Brine Full Load 77°F/Part Load 68°F		Heating Brine Full Load 32°F/Part Load 41°F	
				Capacity BTUH	EER BTU/W	Capacity BTUH	COP
GTC36S1	Full Part	8	1200 850	38,800	17.5	28,800	3.90
				28,000	24.9	22,800	4.40
GTC48S1	Full Part	12	1500 1150	51,000	16.0	37,500	3.60
				38,000	21.5	31,000	4.05
GTC60S1	Full Part	15	1800 1300	61,500	15.5	49,000	3.50
				47,500	20.7	39,500	3.90

MODEL	System Capacity Modulation	Fluid Flow Rate GPM	Airflow CFM	Ground Water Heat Pump — Tested & Certified to ISO 13256-1:1998			
				Cooling — EWT 59°F		Heating — EWT 50°F	
				Capacity BTUH	EER BTU/W	Capacity BTUH	COP
GTC36S1	Full Part	6	1200 850	42,000	21.8	34,000	4.50
				29,600	29.4	25,000	4.80
GTC48S1	Full Part	7	1500 1150	54,000	19.0	46,000	4.20
				40,000	24.5	34,000	4.45
GTC60S1	Full Part	9	1800 1300	63,500	18.8	58,000	4.05
				49,000	24.7	42,000	4.25

Approved Compressor, A-Coil & Blower Section Combinations

Compressor Unit Section	Coil Section	Blower Section
GTC36S1	GTA3600UD1-A	GTB1-A
GTC48S1	GTA4860UD1-A	
GTC60S1		

Ratings Based on Approved Compressor & A-Coil Only

MODEL	System Capacity Modulation	Fluid Flow Rate GPM	Airflow CFM	Ground Loop Heat Pump — Tested & Certified to ISO 13256-1:1998			
				Cooling Brine Full Load 77°F/Part Load 68°F		Heating Brine Full Load 32°F/Part Load 41°F	
				Capacity BTUH	EER BTU/W	Capacity BTUH	COP
GTC36S1	Full Part	8	1200 850	39,000	18.2	27,600	3.90
				27,800	25.0	22,200	4.30
GTC48S1	Full Part	12	1500 1150	51,000	16.6	36,400	3.60
				38,000	21.6	30,400	3.95
GTC60S1	Full Part	15	1800 1300	62,000	16.4	47,000	3.40
				48,000	23.2	37,500	3.90

MODEL	System Capacity Modulation	Fluid Flow Rate GPM	Airflow CFM	Ground Water Heat Pump — Tested & Certified to ISO 13256-1:1998			
				Cooling — EWT 59°F		Heating — EWT 50°F	
				Capacity BTUH	EER BTU/W	Capacity BTUH	COP
GTC36S1	Full Part	6	1200 850	42,000	22.8	33,200	4.45
				29,600	29.5	24,200	4.70
GTC48S1	Full Part	7	1500 1150	54,500	20.1	44,500	4.20
				40,000	24.7	33,400	4.35
GTC60S1	Full Part	9	1800 1300	64,000	20.0	56,000	4.10
				49,000	27.4	40,000	4.35

ISO Standard 13256-1:1998, "Water to Air and Brine to Air Heat Pumps", which includes watt allowance for water pumping.
Cooling capacity based on 80.6°F DB, 66.2°F WB entering air temperature. Heating capacity based on 68°F DB entering air temperature.

Approved Compressor and A-Coil

Compressor Unit Section	Coil Section
GTC36S1	GTA3600UD1-A
GTC48S1	GTA4860UD1-A
GTC60S1	

• Intertek ETL Listed to Standard for Safety Heating and Cooling Equipment ANSI/UL 1995/CSA 22.2 No. 236-05, Third Edition.

PATENT PENDING



For Use with Gas or Oil Furnace as Dual Fuel Installation

The GTC Compressor Unit Sections may be approved for use with certain 3rd Party A-Coils.
Refer to 3rd Party A-Coil Supplier for approved combinations and ratings.

Refrigerant Connections (Self-Sealing Fittings)

Part Number	Description	Line Size O.D.
GTLS-SK4-1	Line Set Stub Kit with Two Pair Ends ①	3/8" & 7/8"
GTLS-SK2-1	Line Set Stub Kit with Single Pair Ends ①	3/8" & 7/8"
GTLS-03-1	3' Line Set with Fittings	3/8" & 7/8"
GTLS-15-1	15' Line Set with Fittings	3/8" & 7/8"
GTLS-25-1	25' Line Set with Fittings	3/8" & 7/8"
GTLS-35-1	35' Line Set with Fittings	3/8" & 7/8"
GTLS-50-1	50' Line Set with Fittings	3/8" & 7/8"

① One pair consists of one each of 3/8" liquid and 7/8" vapor self-sealing fittings with short section of tube with 90° bend and each has 1/4" service port.



GTLS-SK2-1 (Shown)

Horizontal Drain Pan Kit

GTHZ1	Horizontal Drain Pan Kit for GTA "A-Coil" Sections
--------------	--

Remote Condenser Cover

GTLID	Top Cover for GTC Condensing Sections when Installed as Split-System
--------------	--

Filter Rack

FR23	Filter Rack 16x25x1 with MERV 2 Filter (Aluminum mesh washable, maximum velocity 650 FPM)
-------------	--

Optional Field Installed Start Kits for 1-Phase Models ①

Unit Models	Field Installed Part Number
GTC36S1-A	SK114
GTC48S1-A	SK111
GTC60S1-A	SK115

① Start capacitor and potential relay start kit can be used with all -A single phase models only. Increases starting torque 9x. Do not use if CMC-15 is used.

Optional Field Installed Start Kit for 1-Phase Models ②

Unit Models	Field Installed Part Number
All 1-Phase	CMC-15

② PTCR start kit can be used with all -A single phase models. Increases starting torque 2-3x. Not used for -B or -C three phase models. Do not use if SK111, SK114 or SK115 is used.

Ground Loop Accessories

Heat Pump Model	Part Number	Required Quantity	Description
NOTE: Order 1 loop flow center based on required GPM for heat pump and feet of head required for loop:			
All	DORFC-1	1	Loop Flow Center with Cabinet, 230V-60Hz-1Ph, 1 pump, 22 Ft. Hd. @ 16 GPM, double o-ring fittings
All	DORFC-2	1	Loop Flow Center with Cabinet, 230V-60Hz-1Ph, 2 pump, 44 Ft. Hd. @ 16 GPM, double o-ring fittings
All	DORLFCK-1	1	Loop Flow Center Kit containing: (2) 1" barbed 90° double o-ring elbows with 1/4" FPT ports and 8603-026 pressure/temperature test plugs (for heat pump connection). See DORB1-90-4HC for reference (2) 1" barbed straight double o-ring fittings (for loop flow center connection on heat pump side) See DORB1-S-4HC for reference (1) 12' section of 1" ID 150 PSI hose (8) 1" SS hose clamps
NOTE: Order 1 of the following for loop-side connections to loop flow center:			
All	DORB1-S-4HC	1	(2) 1" barbed straight double o-ring fittings with (4) 1" SS hose clamps
All	DORF125-S	1	(2) 1.25" fusion straight double o-ring fittings
Additional accessory items available:			
	HK1-25	Each	(1) 25' section of 1" ID 150 PSI hose



DORFC-2



**Elbow, 1" Hose Barb X Double O-ring with 1/4" Port and Pressure/Temperature Test Plugs
DORB1-90-4HC**



**1" Hose Barb X Double O-ring
DORB1-S-4HC**



**1-1/4" Socket Fusion X Double O-ring
DORF125-S**

Ground Loop Service Accessories

Heat Pump Model	Part Number	Required Quantity	Description
	DORCL1-90	Each	(2) 90° double o-ring quick-connect cam-lever male fittings for flush attachment to loop flow center
	CLB1-S	Each	(2) 1" straight barbed quick-connect cam-lever female fittings to connect to DORCL1-90 fittings above
	GGK-1	Each	(1) Geo-Gooser w/shut-off valve, 0-100 PSI gauge, garden hose connection, P/T fitting 1/8" probe
	DORGHMT	Each	(1) Double o-ring x male garden hose adapter fitting for loop flow center (to burp/boost loop)



**1" Cam Lever Male X Double O-ring
DORCL1-90**



CLB1-S



**Garden Hose Male X O-ring (single) Adapter
DORGHMT**



GGK-1

Ground Water/Water Loop Accessories

Heat Pump Model	Part Number	Required Quantity	Description
All	GWK-1	1	Ground Water Kit containing: (2) 1" MPT 90° double o-ring elbows with 1/4" FPT ports and 8603-026 pressure/temperature test plugs (for heat pump connection). See DORMP1-90 for reference (1) 3/4" FPT 24V brass motorized slow open/close valve with end switch — See 8603-030 for reference
NOTE: Order correct constant flow valve for rated GPM of heat pump, 1 required per unit			
GTC36	CFV-6	1	Constant flow valve, 6 GPM, 3/4" FPT
GTC48	CFV-7	1	Constant flow valve, 7 GPM, 3/4" FPT
GTC60	CFV-9	1	Constant flow valve, 9 GPM, 3/4" FPT



Elbow, 1" MPT X Double
O-ring with 1/4" Port and
Pressure/Temperature Test Plugs
DORMP1-90



8603-030



8603-006

Water Supply Valves

8603-030	Each	3/4" FPT 24V brass slow open/close valve with end switch
8603-006	Each	1" FPT 24V PVC solenoid valve with flow control and internal manual bleed lever

Individual Double O-Ring Fitting Packs (Qty 2 per pack)

DORB1-90-4HC		(2) 1" barbed 90° double o-ring elbows with 1/4" FPT ports, 8603-026 pressure/temperature test plugs, and (4) SS 1" hose clamps
DORB1-S-4HC		(2) 1" barbed straight double o-ring fittings with (4) 1" SS hose clamps
DORMP1-90		(2) 1" MPT 90° double o-ring elbows with 1/4" FPT ports and 8603-026 pressure/temperature test plugs
DORMP1-S		(2) 1" MPT straight double o-ring fittings
DORFP1-S		(2) 1" FPT straight double o-ring fittings
DORS1-S		(2) 1" copper sweat straight double o-ring fittings with 1/4" FPT ports and 8603-026 pressure/temperature test plugs



1" MPT X Double O-ring
DORMP1-S



1" Swivel X Double O-ring
DORFP1-S



1" Copper Sweat X Double O-ring with 1/4"
FPT Port & Pressure/Temperature Test Plugs
DORS1-S

Ground Water/Water Loop Service Accessories

All	8603-017	Each	Flow Meter, 1-17 GPM, 1" FPT
All	8603-026	Each	1/4" pressure/temperature test plug
All	8603-027	Each	1/4" FPT gauge adapter w/ 1/8" heavy duty probe
All	8603-028	Each	1/4" MPT 0-100 PSI gauge
All	8603-029	Each	Pocket thermometer, 1/8" probe, 0 to +220F



8603-017



8603-026



8603-027



8603-028



8603-029

Evaporator and Blower in Horizontal Position (Remote Compressor Section)

NOTE:
Requires
horizontal
drain pan kit
Model GTHZ-1

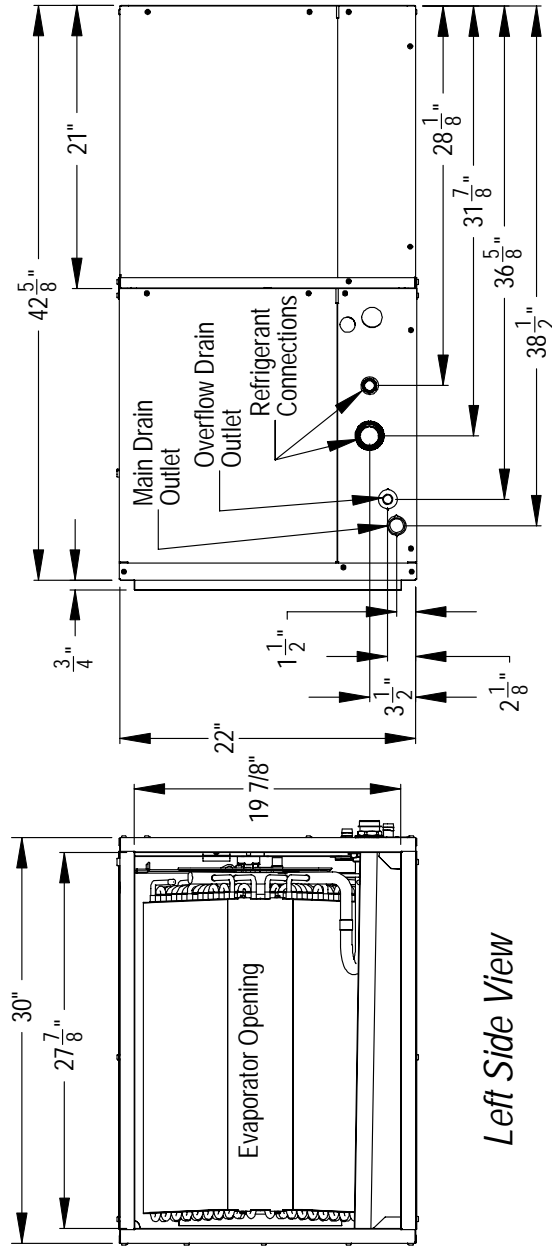
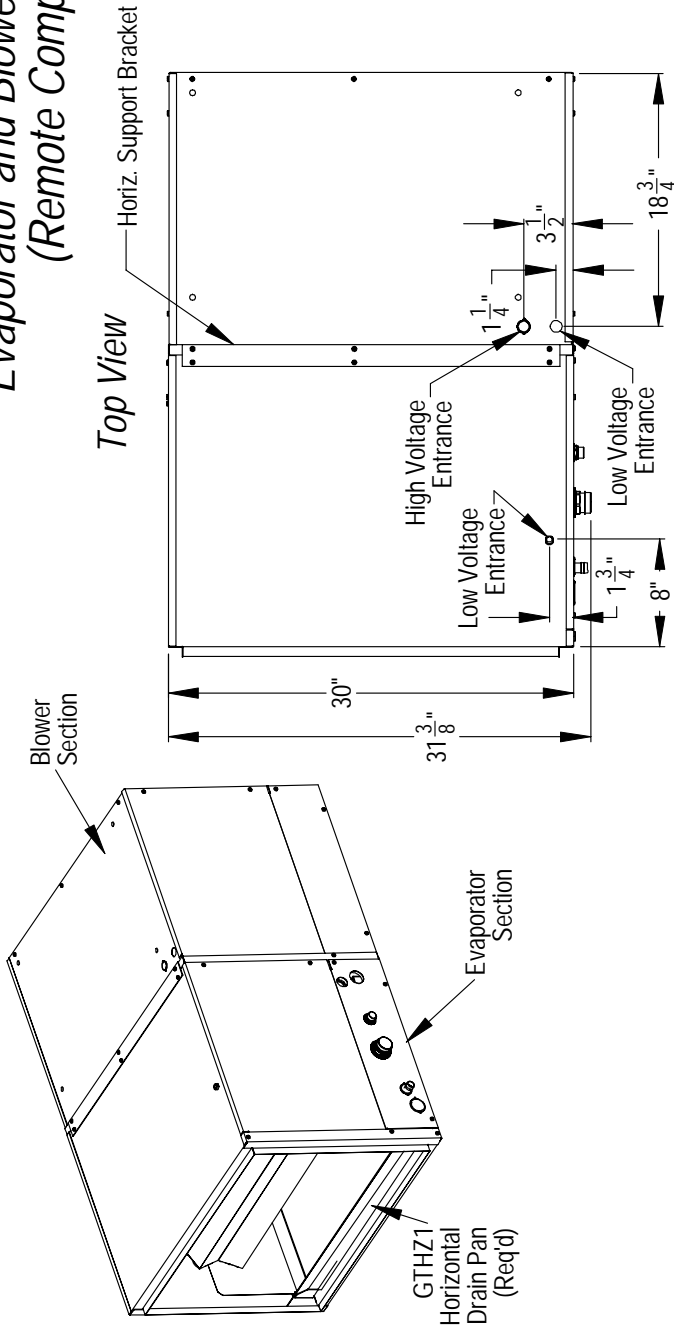

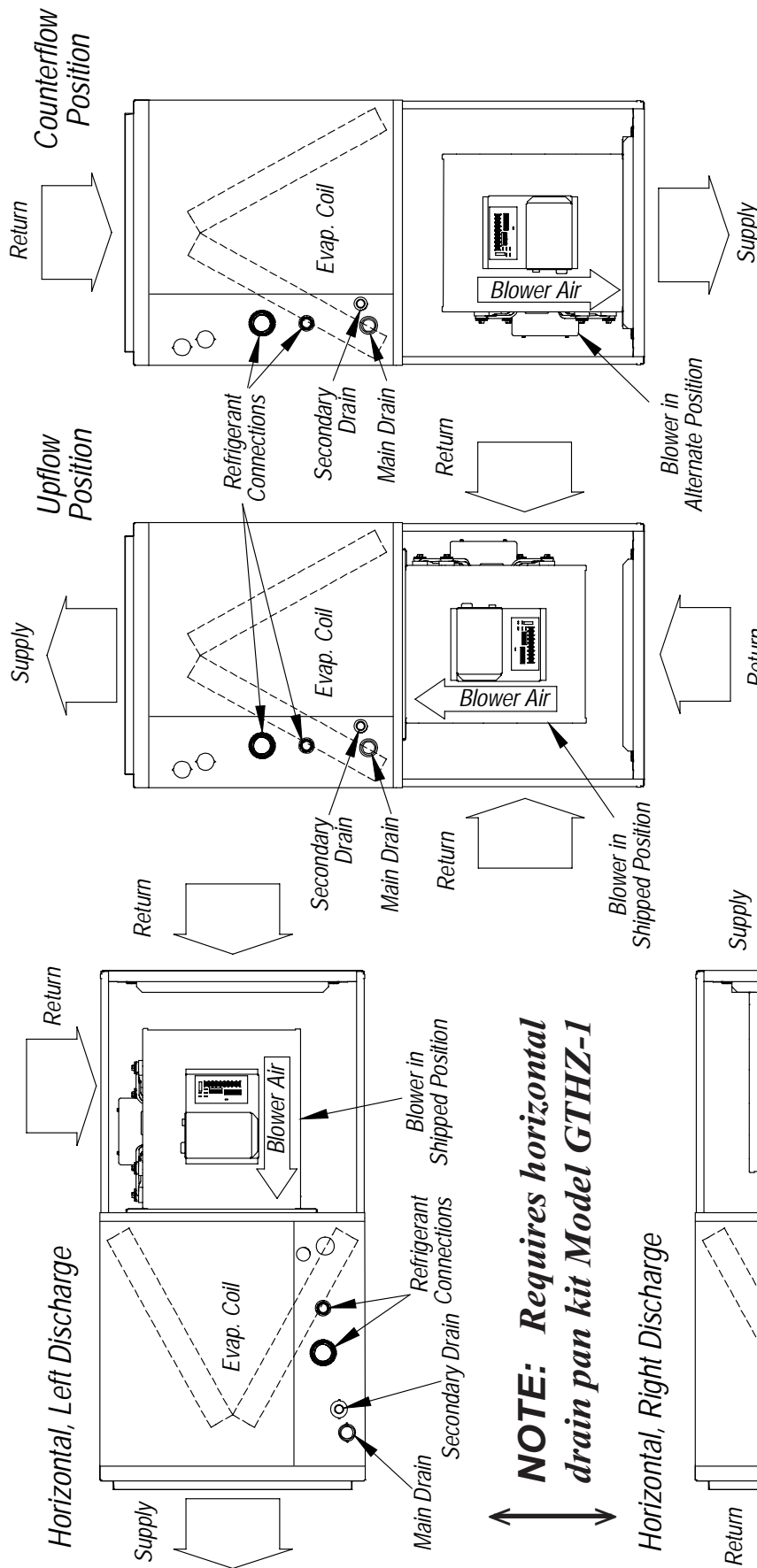

NOTE: Requires horizontal drain pan kit Model GTHZ-1

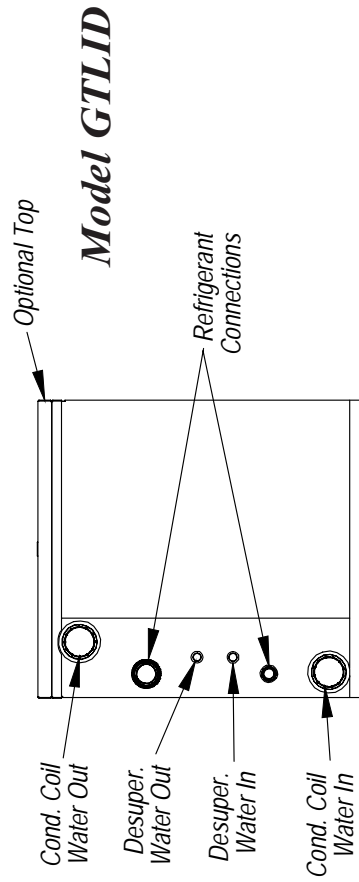

Air Filter Required on Return Air Side for All Installations

Upflow installations can use (1) FR23 (16x25x1) or field supplied equivalent on either side of the blower section. Use of (2) on both sides is optional.

Bottom return for upflow and top return for downflow must be field supplied.

For horizontal attic or crawl space installations filter arrangement must be field supplied & should be located in readily accessible location for the user.

See additional information on Pages 12 & 13.

Remote Condenser Section

MIS-2826

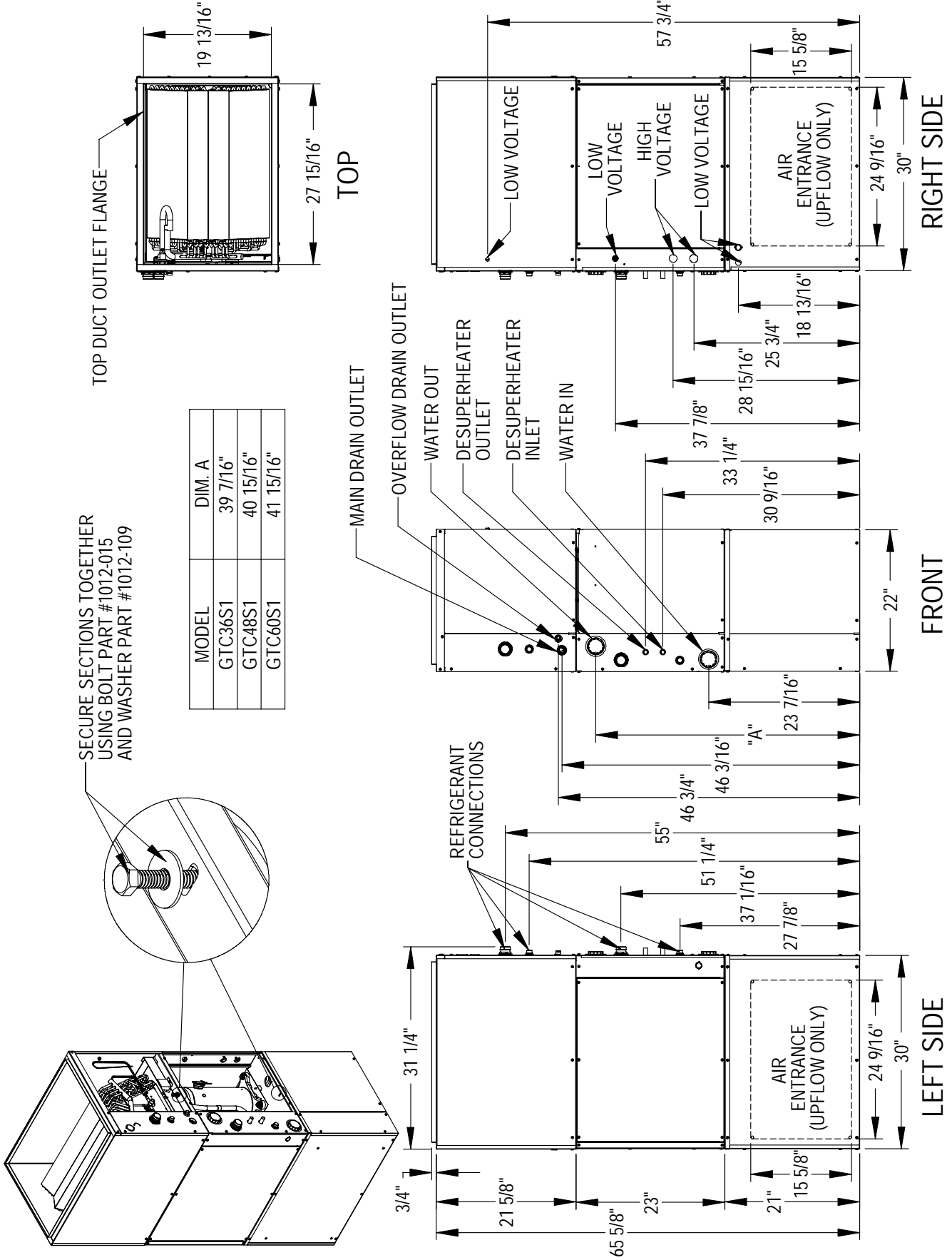

MODEL	DIM. A
GTC36S1	39 7/16"
GTC48S1	40 15/16"
GTC60S1	41 15/16"

MIS-2821 A

NOTE:
 See Page 20 for physical dimensions of GTA coil if removed from casing for installation on a fossil-fuel furnace.

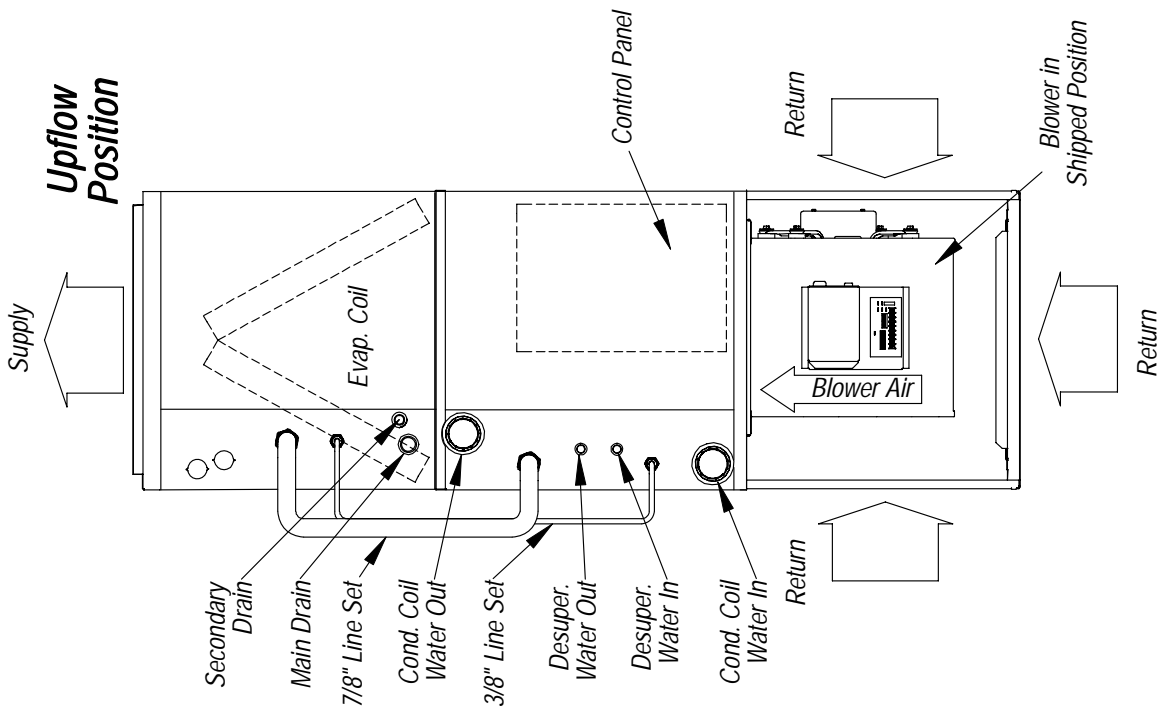
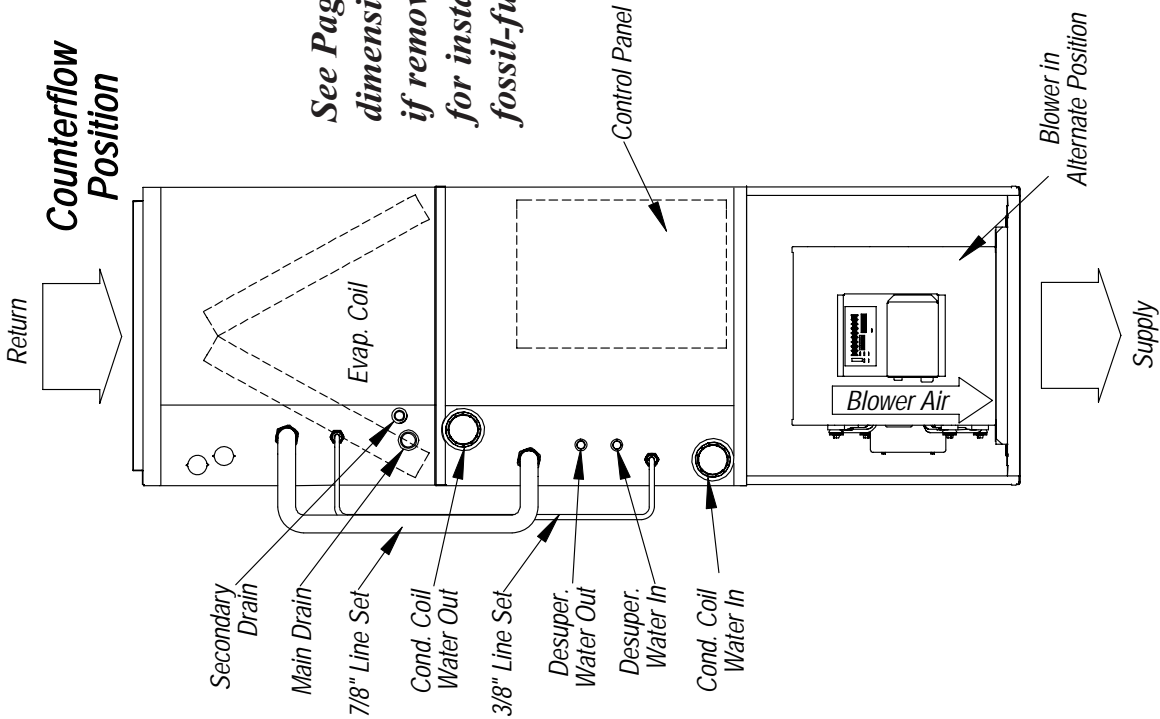

Air Filter Required on Return Air Side for All Installations
 Upflow installations can use (1) FR23 (16x25x1) or field supplied equivalent on either side of the blower section. Use of (2) on both sides is optional.
 Bottom return for upflow and top return for downflow must be field supplied.
 See additional information on Pages 12 & 13.

MIS-2828

Filter Application Table

Many standard size filters are represented below since there can be a wide variety of possibilities depending upon application position of the heat pump system and the return air duct installation.

Filter Nominal Size	Surface Area FT ²	Filter Type	Airflow CFM Capability @ 300 FPM Velocity	Airflow CFM Capability @ 500 FPM Velocity	Airflow CFM Capability @ 625 FPM Velocity
10" X 20" X 1"	1.39	1" Fiberglass Disposable	415	Not Recommended	Not Recommended
12" X 20" X 1"	1.67		500		
14" X 20" X 1"	1.94		580		
14" X 25" X 1"	2.43		730		
16" X 20" X 1"	2.22		670		
16" X 25" X 1"	2.78		840		
20" X 20" X 1"	2.78		840		
20" X 25" X 1"	3.47		1050		
24" X 24" X 1"	4.00		1200		
10" X 20" X 2"	1.39		2" Std. Fiberglass Disposable		
12" X 24" X 2"	2.00	600		1000	
14" X 20" X 2"	1.94	580		975	
14" X 25" X 2"	2.43	730		1215	
16" X 20" X 2"	2.22	670		1120	
16" X 25" X 2"	2.78	840		1400	
20" X 20" X 2"	2.78	840		1400	
20" X 25" X 2"	3.47	1050		1750	
24" X 24" X 2"	4.00	1200		2000	
10" X 20" X 1"	1.39	1" Pleated Filter		425	700
12" X 24" X 1"	2.00		600	1000	
14" X 20" X 1"	1.94		590	980	
14" X 25" X 1"	2.43		730	1215	
16" X 20" X 1"	2.22		670	1115	
16" X 25" X 1"	2.78		840	1400	
20" X 20" X 1"	2.78		840	1400	
20" X 25" X 1"	3.47		1050	1740	
24" X 24" X 1"	4.00		1200	2000	
10" X 20" X 2"	1.39		2" Pleated Filter	425	700
12" X 24" X 2"	2.00	600		1000	1250
14" X 20" X 2"	1.94	590		980	1215
14" X 25" X 2"	2.43	730		1215	1520
16" X 20" X 2"	2.22	670		1115	1400
16" X 25" X 2"	2.78	840		1400	1740
20" X 20" X 2"	2.78	840		1400	1740
20" X 25" X 2"	3.47	1050		1740	2170
24" X 24" X 2"	4.00	1200		2000	2500
12" X 24" X 4"	2	4" Pleated Filter		600	1000
16" X 20" X 4"	2.22		670	1115	1400
20" X 20" X 4"	2.78		840	1400	1740
20" X 25" X 4"	3.47		1050	1740	2170
24" X 24" X 4"	4		1200	2000	2500

NOTE: FR23 16x25x1 side filter rack has a washable multi-layer aluminum mesh filter that is rated at 650 FPM maximum.

Filter Application for All Installation Positions

UPFLOW

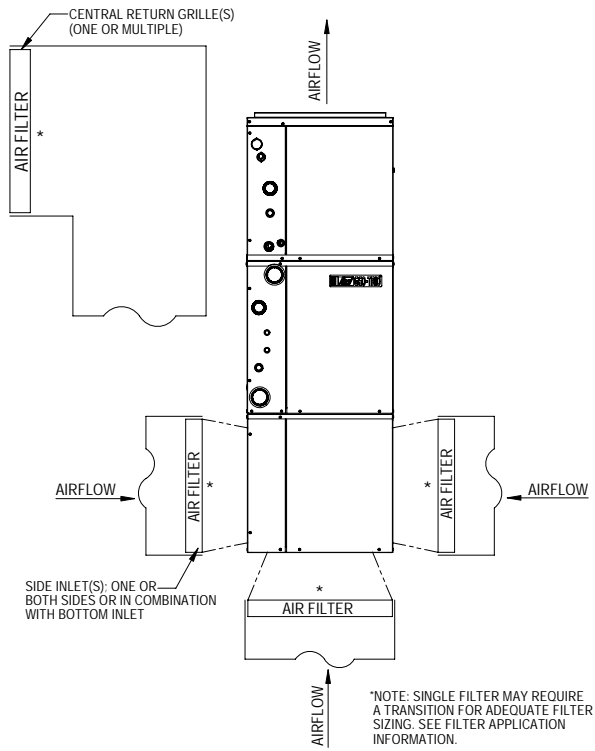

MIS-2881

COUNTERFLOW

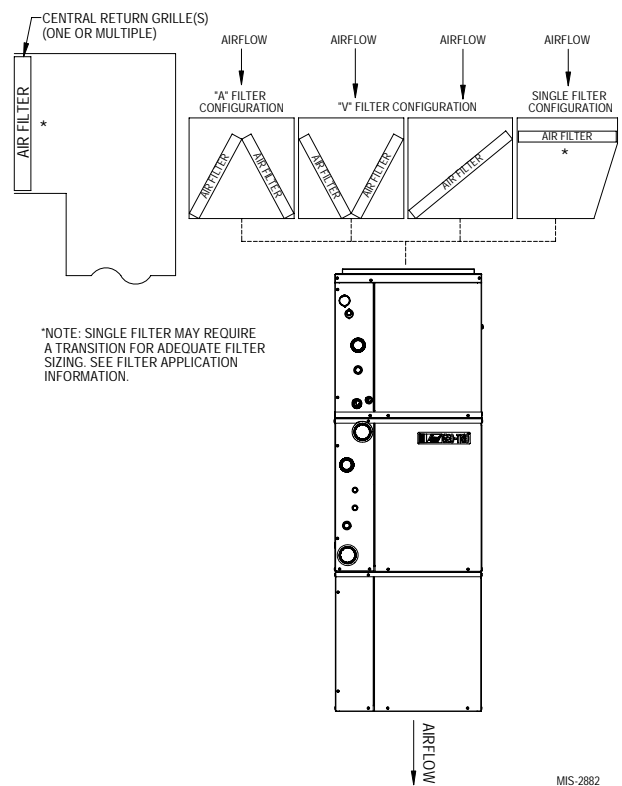

MIS-2882

HORIZONTAL LEFT DISCHARGE

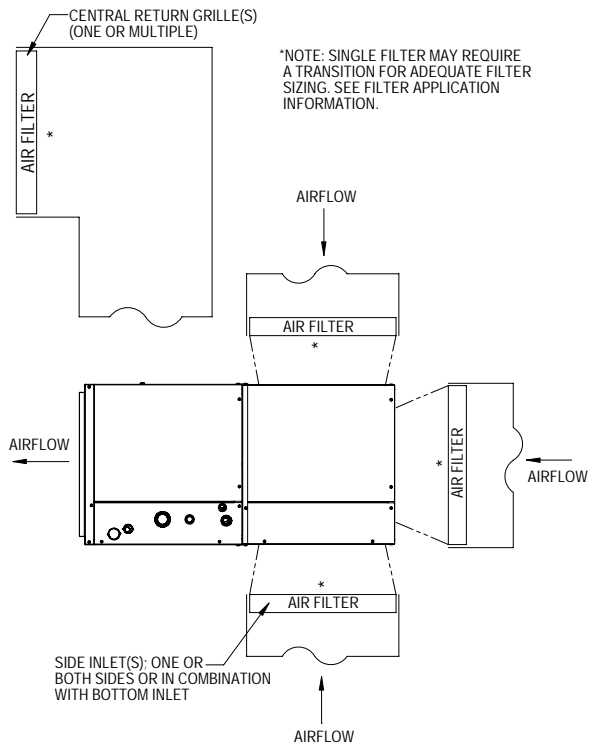

MIS-2883

HORIZONTAL FRONT DISCHARGE

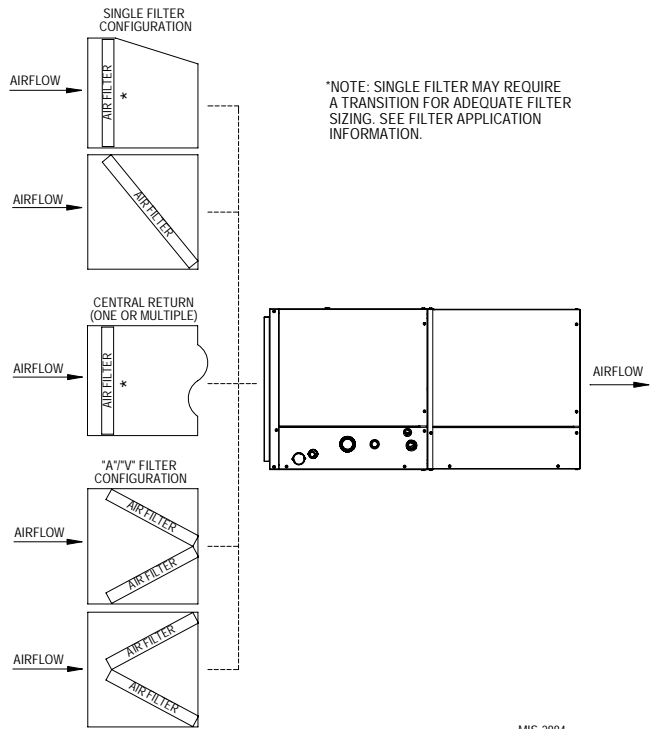

MIS-2884

FILTERS SHOULD ALWAYS BE APPLIED IN A MANNER THAT MAKES THEM EASY TO ACCESS & CHANGE.

GTC36S1 Matched with GTA3600UD1-A Coil

Full Load Capacities based upon rated flow of 8 GPM of 15% methanol/mass at 1200 CFM airflow.

COOLING FULL LOAD

Entering Fluid Temp. (°F)	Entering Air Temp. (°F)	Total Capacity (MBtuH)	Sensible Capacity (MBtuH)	Sensible to Total Ratio	Power Input (KW)	Heat of Rejection (MBtuH)	EER
50°	70° DB 59° WB	40.0	28.9	0.72	1.50	45.1	26.6
60°		38.1	28.1	0.74	1.74	44.0	21.8
70°		36.2	27.4	0.76	1.99	43.0	18.2
80°		34.3	26.6	0.78	2.23	41.9	15.4
90°		32.4	25.9	0.80	2.47	40.8	13.1
100°		30.5	25.1	0.82	2.72	39.8	11.2
110°		28.6	24.3	0.85	2.96	38.7	9.7
50°	75° DB 63° WB	43.0	30.1	0.70	1.51	48.2	28.4
60°		41.0	29.3	0.72	1.76	47.0	23.2
70°		38.9	28.5	0.73	2.01	45.8	19.3
80°		36.9	27.7	0.75	2.26	44.6	16.3
90°		34.9	26.9	0.77	2.51	43.4	13.9
100°		32.8	26.1	0.80	2.76	42.2	11.9
110°		30.8	25.3	0.82	3.01	41.1	10.2
50°	80° DB 67° WB	46.2	31.2	0.68	1.54	51.4	30.0
60°		44.0	30.4	0.69	1.79	50.1	24.6
70°		41.8	29.6	0.71	2.04	48.8	20.5
80°		39.6	28.8	0.73	2.29	47.4	17.3
90°		37.4	27.9	0.75	2.54	46.1	14.7
100°		35.2	27.1	0.77	2.79	44.8	12.6
110°		33.0	26.3	0.80	3.04	43.4	10.9
50°	85° DB 71° WB	49.5	32.3	0.65	1.56	54.8	31.7
60°		47.1	31.5	0.67	1.82	53.3	26.0
70°		44.8	30.6	0.68	2.07	51.9	21.6
80°		42.5	29.8	0.70	2.32	50.4	18.3
90°		40.1	28.9	0.72	2.58	48.9	15.6
100°		37.8	28.1	0.74	2.83	47.4	13.3
110°		35.4	27.2	0.77	3.08	45.9	11.5

HEATING FULL LOAD

Entering Fluid Temp. (°F)	Entering Air Temp. (°F)	Total Capacity (MBtuH)	Leaving Air Temp. (°F)	Power Input (KW)	Heat of Absorption (MBtuH)	COP
25°	65°	23.7	83.3	1.92	17.0	3.7
30°		26.3	85.3	1.98	19.3	3.9
40°		31.4	89.3	2.12	24.0	4.3
50°		36.6	93.2	2.26	28.7	4.8
60°		41.8	97.2	2.39	33.4	5.1
70°		46.9	101.2	2.53	38.1	5.4
80°		52.1	105.2	2.67	42.8	5.8
25°	70°	23.2	87.9	1.97	16.5	3.5
30°		25.7	89.8	2.04	18.7	3.7
40°		30.7	93.7	2.18	23.3	4.1
50°		35.8	97.6	2.32	27.9	4.5
60°		40.8	101.5	2.46	32.4	4.8
70°		45.9	105.4	2.60	37.0	5.2
80°		50.9	109.3	2.74	41.6	5.5
25°	75°	23.4	93.1	2.21	16.0	3.1
30°		26.0	95.0	2.29	18.2	3.3
40°		31.1	99.0	2.44	22.6	3.7
50°		36.2	102.9	2.60	27.0	4.1
60°		41.3	106.8	2.76	31.5	4.4
70°		46.4	110.8	2.92	35.9	4.7
80°		51.5	114.7	3.07	40.3	4.9

Part Load Capacities based upon rated flow of 8 GPM of 15% methanol/mass at 850 CFM airflow.

COOLING PART LOAD

Entering Fluid Temp. (°F)	Entering Air Temp. (°F)	Total Capacity (MBtuH)	Sensible Capacity (MBtuH)	Sensible to Total Ratio	Power Input (KW)	Heat of Rejection (MBtuH)	EER
50°	70° DB 59° WB	26.9	22.0	0.82	0.73	29.4	37.0
60°		25.1	20.8	0.83	0.93	28.3	27.1
70°		23.3	19.6	0.84	1.12	27.1	20.7
80°		21.4	18.4	0.86	1.32	26.0	16.2
90°		19.6	17.2	0.88	1.52	24.8	12.9
100°		17.8	16.0	0.90	1.72	23.7	10.3
110°		16.0	14.8	0.93	1.92	22.5	8.3
50°	75° DB 63° WB	29.0	22.9	0.79	0.73	31.5	39.6
60°		27.0	21.6	0.80	0.94	30.2	28.9
70°		25.0	20.4	0.81	1.14	28.9	22.0
80°		23.1	19.2	0.83	1.34	27.7	17.2
90°		21.1	17.9	0.85	1.55	26.4	13.6
100°		19.1	16.7	0.87	1.75	25.1	10.9
110°		17.2	15.4	0.90	1.95	23.9	8.8
50°	80° DB 67° WB	31.1	23.7	0.75	0.75	33.6	31.1
60°		29.0	22.5	0.77	0.95	32.2	27.2
70°		26.9	21.2	0.79	1.15	30.8	23.3
80°		24.8	19.9	0.81	1.36	29.4	19.4
90°		22.7	18.6	0.82	1.56	28.0	15.5
100°		20.6	17.3	0.84	1.77	26.6	11.6
110°		18.4	16.0	0.86	1.97	25.2	7.7
50°	85° DB 71° WB	33.3	24.6	0.74	0.76	35.9	44.0
60°		31.1	23.2	0.75	0.96	34.4	32.2
70°		28.8	21.9	0.76	1.17	32.8	24.6
80°		26.6	20.6	0.77	1.38	31.3	19.3
90°		24.3	19.2	0.79	1.59	29.7	15.3
100°		22.0	17.9	0.81	1.79	28.1	12.3
110°		19.8	16.6	0.84	2.00	26.6	9.9

HEATING PART LOAD

Entering Fluid Temp. (°F)	Entering Air Temp. (°F)	Total Capacity (MBtuH)	Leaving Air Temp. (°F)	Power Input (KW)	Heat of Absorption (MBtuH)	COP
25°	65°	18.3	85.0	1.48	13.1	3.7
30°		20.0	86.8	1.49	14.8	3.9
40°		23.4	90.4	1.52	18.0	4.5
50°		26.7	94.1	1.55	21.3	5.1
60°		30.1	97.7	1.57	24.6	5.6
70°		33.4	101.4	1.60	27.9	6.1
80°		36.8	105.0	1.63	31.1	6.6
25°	70°	17.9	89.5	1.52	12.7	3.5
30°		19.6	91.3	1.53	14.3	3.7
40°		22.8	94.9	1.56	17.5	4.3
50°		26.1	98.4	1.59	20.7	4.8
60°		29.4	102.0	1.62	23.9	5.3
70°		32.7	105.6	1.64	27.0	5.8
80°		35.9	109.1	1.67	30.2	6.3
25°	75°	18.1	94.7	1.70	12.4	3.1
30°		19.8	96.5	1.72	13.9	3.4
40°		23.1	100.1	1.75	17.0	3.9
50°		26.4	103.8	1.78	20.1	4.3
60°		29.7	107.4	1.81	23.2	4.8
70°		33.0	111.0	1.85	26.2	5.2
80°		36.3	114.6	1.88	29.3	5.7

GTC36S1 Matched with GTA3600UD1-A Coil

Full Load Capacities based upon rated flow of 6 GPM water at 1200 CFM airflow.

COOLING FULL LOAD

Entering Fluid Temp. (°F)	Entering Air Temp. (°F)	Total Capacity (MBtuH)	Sensible Capacity (MBtuH)	Sensible to Total Ratio	Power Input (KW)	Heat of Rejection (MBtuH)	EER
50°	70° DB 59° WB	35.8	25.7	0.72	1.56	41.1	23.0
60°		35.8	26.2	0.73	1.71	41.6	20.9
70°		35.7	26.7	0.75	1.86	42.1	19.2
80°		35.7	27.1	0.76	2.01	42.6	17.7
90°		35.7	26.7	0.75	1.86	42.1	19.2
100°		35.8	26.2	0.73	1.71	41.6	20.9
110°		35.8	25.7	0.72	1.56	41.1	23.0
50°	75° DB 63° WB	38.5	26.8	0.70	1.58	43.9	24.4
60°		38.5	27.3	0.76	1.73	44.4	22.2
70°		38.4	27.8	0.75	1.88	44.8	20.4
80°		38.4	28.2	0.74	2.04	45.3	18.8
90°		38.4	27.8	0.72	1.88	44.8	20.4
100°		38.5	27.3	0.71	1.73	44.4	22.2
110°		38.5	26.8	0.70	1.58	43.9	24.4
50°	80° DB 67° WB	41.3	27.8	0.75	1.60	46.8	25.9
60°		41.3	28.3	0.74	1.75	49.2	23.6
70°		41.2	28.8	0.72	1.91	48.7	21.6
80°		41.2	29.3	0.71	2.07	48.3	19.9
90°		41.2	28.8	0.70	1.91	47.8	21.6
100°		41.3	28.3	0.69	1.75	47.3	23.6
110°		41.3	27.8	0.67	1.60	46.8	25.9
50°	85° DB 71° WB	44.3	28.8	0.65	1.62	49.8	27.4
60°		44.3	29.3	0.66	1.78	50.3	24.9
70°		44.2	29.8	0.67	1.94	50.8	22.8
80°		44.2	30.3	0.69	2.10	51.3	21.1
90°		44.2	29.8	0.67	1.94	50.8	22.8
100°		44.3	29.3	0.66	1.78	50.3	24.9
110°		44.3	28.8	0.65	1.62	49.8	27.4

HEATING FULL LOAD

Entering Fluid Temp. (°F)	Entering Air Temp. (°F)	Total Capacity (MBtuH)	Leaving Air Temp. (°F)	Power Input (KW)	Heat of Absorption (MBtuH)	COP
25°	65°	30.4	88.5	2.00	23.6	4.5
30°		32.9	90.4	2.08	25.8	4.6
40°		35.5	92.4	2.16	28.1	4.8
50°		40.5	96.2	2.32	32.5	5.1
60°		45.5	100.1	2.49	37.0	5.4
70°		50.5	104.0	2.65	41.5	5.6
80°		55.5	107.8	2.81	45.9	5.8
25°	70°	29.8	93.0	2.06	22.7	6.0
30°		32.2	94.9	2.14	24.9	6.2
40°		34.7	96.7	2.22	27.1	4.6
50°		39.6	100.5	2.39	31.4	4.8
60°		44.5	104.3	2.55	35.7	5.1
70°		49.4	108.1	2.72	40.1	5.4
80°		54.3	111.9	2.88	44.4	5.6
25°	75°	30.1	98.2	2.31	22.2	3.8
30°		32.6	100.1	2.40	24.4	4.0
40°		35.0	102.0	2.50	26.5	4.1
50°		40.0	105.9	2.68	30.8	4.4
60°		44.9	109.7	2.87	35.2	4.6
70°		49.9	113.5	3.05	39.5	4.8
80°		54.9	117.3	3.24	43.8	5.0

Part Load Capacities based upon rated flow of 6 GPM water at 850 CFM airflow.

COOLING PART LOAD

Entering Fluid Temp. (°F)	Entering Air Temp. (°F)	Total Capacity (MBtuH)	Sensible Capacity (MBtuH)	Sensible to Total Ratio	Power Input (KW)	Heat of Rejection (MBtuH)	EER
50°	70° DB 59° WB	28.7	20.5	0.72	0.73	31.2	39.3
60°		27.6	20.1	0.73	0.86	30.6	32.2
70°		26.6	19.6	0.74	0.99	30.0	26.9
80°		25.5	19.1	0.75	1.12	29.3	22.9
90°		24.5	18.7	0.76	1.25	28.7	19.7
100°		23.4	18.2	0.78	1.37	28.1	17.1
110°		22.4	17.7	0.79	1.50	27.5	14.9
50°	75° DB 63° WB	30.8	21.4	0.69	0.74	33.4	41.7
60°		29.7	20.9	0.70	0.87	32.7	34.2
70°		28.6	20.4	0.71	1.00	32.0	28.6
80°		27.5	19.9	0.73	1.13	31.3	24.3
90°		26.3	19.4	0.74	1.26	30.6	20.9
100°		25.2	18.9	0.75	1.39	30.0	18.1
110°		24.1	18.5	0.77	1.52	29.3	15.8
50°	80° DB 67° WB	33.1	22.2	0.67	0.75	35.7	44.2
60°		31.9	21.7	0.68	0.88	34.9	36.2
70°		30.7	21.2	0.69	1.01	34.2	28.7
80°		29.5	20.7	0.70	1.15	33.4	25.7
90°		28.3	20.2	0.71	1.28	32.6	22.7
100°		27.1	19.7	0.73	1.41	31.9	19.8
110°		25.9	19.2	0.74	1.54	31.1	16.8
50°	85° DB 71° WB	35.5	23.0	0.65	0.76	38.1	46.7
60°		34.2	22.4	0.66	0.89	37.3	38.2
70°		32.9	21.9	0.67	1.03	36.4	32.0
80°		31.6	21.4	0.68	1.16	35.6	27.2
90°		30.3	20.9	0.69	1.30	34.7	23.4
100°		29.0	20.4	0.70	1.43	33.9	20.3
110°		27.7	19.8	0.72	1.56	33.1	17.7

HEATING PART LOAD

Entering Fluid Temp. (°F)	Entering Air Temp. (°F)	Total Capacity (MBtuH)	Leaving Air Temp. (°F)	Power Input (KW)	Heat of Absorption (MBtuH)	COP
25°	65°	23.0	90.0	1.43	18.1	4.7
30°		24.5	91.7	1.46	19.6	4.9
40°		26.1	93.4	1.48	21.0	5.2
50°		29.2	96.8	1.53	24.0	5.6
60°		32.3	100.2	1.58	26.9	6.0
70°		35.4	103.6	1.62	29.9	6.4
80°		38.5	107.0	1.67	32.8	6.8
25°	70°	22.5	94.5	1.47	17.4	7.1
30°		24.0	96.1	1.50	18.9	7.5
40°		25.5	97.8	1.52	20.3	7.9
50°		28.5	101.1	1.57	23.2	8.2
60°		31.6	104.4	1.62	26.1	8.6
70°		34.6	107.7	1.67	28.9	8.9
80°		37.7	111.0	1.71	31.8	9.3
25°	75°	22.7	99.7	1.65	17.1	4.0
30°		24.2	101.4	1.68	18.5	4.2
40°		25.8	103.1	1.71	20.0	4.4
50°		28.9	106.4	1.76	22.8	4.8
60°		31.9	109.8	1.82	25.7	5.2
70°		35.0	113.1	1.87	28.6	5.5
80°		38.1	116.5	1.93	31.5	5.8

GTC48S1 Matched with GTA4860UD1-A Coil

Full Load Capacities based upon rated flow of 12 GPM of 15% methanol/mass at 1500 CFM airflow.

COOLING FULL LOAD

Entering Fluid Temp. (°F)	Entering Air Temp. (°F)	Total Capacity (MBtuH)	Sensible Capacity (MBtuH)	Sensible to Total Ratio	Power Input (KW)	Heat of Rejection (MBtuH)	EER
50°	70° DB 59° WB	51.4	36.1	0.70	2.42	59.7	21.3
60°		49.0	35.1	0.71	2.71	58.3	18.1
70°		46.7	34.0	0.73	3.01	56.9	15.5
80°		44.3	33.0	0.74	3.31	55.6	13.4
90°		41.9	31.9	0.76	3.61	54.2	11.6
100°		39.5	30.9	0.78	3.90	52.8	10.1
110°		37.1	29.8	0.80	4.20	51.5	8.8
50°	75° DB 63° WB	55.3	37.6	0.68	2.44	63.6	22.7
60°		52.8	36.5	0.69	2.74	62.1	19.2
70°		50.2	35.4	0.71	3.05	60.6	16.5
80°		47.6	34.3	0.72	3.35	59.1	14.2
90°		45.1	33.2	0.74	3.66	57.6	12.3
100°		42.5	32.2	0.76	3.97	56.0	10.7
110°		39.9	31.1	0.78	4.27	54.5	9.3
50°	80° DB 67° WB	59.4	39.0	0.66	2.48	67.9	23.9
60°		56.6	37.9	0.67	2.79	66.1	20.3
70°		53.9	36.8	0.68	3.09	64.4	17.4
80°		51.1	35.6	0.70	3.39	62.7	15.1
90°		48.4	34.5	0.71	3.70	61.0	13.1
100°		45.6	33.4	0.73	4.00	59.3	11.4
110°		42.9	32.2	0.75	4.31	57.6	10.0
50°	85° DB 71° WB	63.7	40.4	0.63	2.52	72.2	25.3
60°		60.7	39.2	0.65	2.83	70.4	21.5
70°		57.8	38.0	0.66	3.13	68.5	18.4
80°		54.8	36.9	0.67	3.44	66.6	15.9
90°		51.9	35.7	0.69	3.75	64.7	13.8
100°		48.9	34.5	0.71	4.06	62.8	12.0
110°		46.0	33.4	0.73	4.37	60.9	10.5

HEATING FULL LOAD

Entering Fluid Temp. (°F)	Entering Air Temp. (°F)	Total Capacity (MBtuH)	Leaving Air Temp. (°F)	Power Input (KW)	Heat of Absorption (MBtuH)	COP
25°	65°	34.1	86.1	2.93	23.8	3.4
30°		37.2	88.0	3.04	26.5	3.6
40°		43.5	91.8	3.24	32.1	3.9
50°		49.7	95.7	3.44	37.6	4.2
60°		56.0	99.5	3.64	43.2	4.5
70°		62.2	103.4	3.85	48.7	4.7
80°		68.4	107.2	4.05	54.3	5.0
25°	70°	33.4	90.6	3.01	23.1	3.3
30°		36.4	92.5	3.12	25.8	3.4
40°		42.5	96.2	3.33	31.2	3.7
50°		48.6	100.0	3.53	36.5	4.0
60°		54.7	103.8	3.74	41.9	4.3
70°		60.8	107.5	3.95	47.3	4.5
80°		66.9	111.3	4.16	52.7	4.8
25°	75°	33.7	95.8	3.38	22.4	2.9
30°		36.8	97.7	3.50	25.0	3.1
40°		43.0	101.5	3.73	30.2	3.4
50°		49.1	105.3	3.97	35.4	3.6
60°		55.3	109.1	4.20	40.7	3.8
70°		61.5	112.9	4.43	45.9	4.1
80°		67.6	116.8	4.67	51.1	4.3

Part Load Capacities based upon rated flow of 12 GPM of 15% methanol/mass at 1150 CFM airflow.

COOLING PART LOAD

Entering Fluid Temp. (°F)	Entering Air Temp. (°F)	Total Capacity (MBtuH)	Sensible Capacity (MBtuH)	Sensible to Total Ratio	Power Input (KW)	Heat of Rejection (MBtuH)	EER
50°	70° DB 59° WB	39.1	28.3	0.72	1.35	43.7	29.0
60°		37.1	27.5	0.74	1.60	42.6	23.2
70°		35.1	26.6	0.76	1.86	41.4	18.9
80°		33.1	25.8	0.78	2.11	40.3	15.7
90°		31.1	25.0	0.80	2.37	39.2	13.1
100°		29.1	24.2	0.83	2.62	38.0	11.1
110°		27.1	23.3	0.86	2.88	36.9	9.4
50°	75° DB 63° WB	42.1	29.5	0.70	1.36	46.7	31.0
60°		39.9	28.6	0.72	1.62	45.4	24.7
70°		37.7	27.7	0.73	1.88	44.2	20.1
80°		35.6	26.9	0.76	2.14	42.9	16.6
90°		33.4	26.0	0.78	2.41	41.7	13.9
100°		31.3	25.2	0.80	2.67	40.4	11.7
110°		29.1	24.3	0.83	2.93	39.1	9.9
50°	80° DB 67° WB	45.2	30.6	0.67	1.38	49.9	27.1
60°		42.8	29.7	0.69	1.64	48.5	24.2
70°		40.5	28.8	0.71	1.91	47.0	21.3
80°		38.2	27.9	0.73	2.17	45.6	18.3
90°		35.9	27.0	0.75	2.43	44.2	15.4
100°		33.6	26.1	0.78	2.69	42.8	12.5
110°		31.3	25.2	0.80	2.95	41.4	9.6
50°	85° DB 71° WB	48.4	31.7	0.65	1.40	53.2	34.5
60°		45.9	30.7	0.67	1.67	51.6	27.5
70°		43.4	29.8	0.69	1.93	50.0	22.5
80°		41.0	28.9	0.70	2.20	48.5	18.6
90°		38.5	27.9	0.73	2.47	46.9	15.6
100°		36.0	27.0	0.75	2.73	45.3	13.2
110°		33.5	26.1	0.78	3.00	43.8	11.2

HEATING PART LOAD

Entering Fluid Temp. (°F)	Entering Air Temp. (°F)	Total Capacity (MBtuH)	Leaving Air Temp. (°F)	Power Input (KW)	Heat of Absorption (MBtuH)	COP
25°	65°	23.8	85.5	2.17	16.1	3.2
30°		26.3	87.7	2.21	18.5	3.5
40°		31.3	92.0	2.28	23.3	4.0
50°		36.3	96.3	2.35	28.1	4.5
60°		41.4	100.6	2.43	32.9	5.0
70°		46.4	104.9	2.50	37.7	5.4
80°		51.4	109.2	2.57	42.4	5.9
25°	70°	23.3	90.0	2.23	15.7	3.1
30°		25.7	92.2	2.27	18.0	3.3
40°		30.6	96.4	2.34	22.6	3.8
50°		35.5	100.6	2.42	27.3	4.3
60°		40.4	104.8	2.49	31.9	4.7
70°		45.3	109.0	2.57	36.6	5.2
80°		50.2	113.3	2.64	41.2	5.6
25°	75°	23.5	95.3	2.51	15.2	2.8
30°		26.0	97.4	2.55	17.4	3.0
40°		31.0	101.7	2.63	22.0	3.4
50°		35.9	105.9	2.71	26.5	3.9
60°		40.9	110.2	2.80	31.0	4.3
70°		45.8	114.5	2.88	35.5	4.7
80°		50.8	118.7	2.97	40.0	5.0

GTC48S1 Matched with GTA4860UD1-A Coil

Full Load Capacities based upon rated flow of 7 GPM water at 1500 CFM airflow.

COOLING FULL LOAD

Entering Fluid Temp. (°F)	Entering Air Temp. (°F)	Total Capacity (MBtuH)	Sensible Capacity (MBtuH)	Sensible to Total Ratio	Power Input (KW)	Heat of Rejection (MBtuH)	EER
50°	70° DB 59° WB	48.5	34.1	0.70	2.44	56.8	19.9
60°		47.7	33.7	0.71	2.63	56.7	18.2
70°		47.0	33.4	0.71	2.82	56.6	16.7
80°		46.2	33.0	0.71	3.01	56.5	15.4
90°		47.0	33.4	0.71	2.82	56.6	16.7
100°		47.7	33.7	0.71	2.63	56.7	18.2
110°		48.5	34.1	0.70	2.44	56.8	19.9
50°	75° DB 63° WB	52.2	35.5	0.68	2.47	60.6	21.1
60°		51.4	35.1	0.70	2.66	60.4	19.3
70°		50.5	34.7	0.69	2.85	60.3	17.7
80°		49.7	34.4	0.69	3.05	60.1	16.3
90°		50.5	34.7	0.69	2.85	60.3	17.7
100°		51.4	35.1	0.68	2.66	60.4	19.3
110°		52.2	35.5	0.68	2.47	60.6	21.1
50°	80° DB 67° WB	56.0	36.8	0.66	2.50	64.5	22.4
60°		55.1	36.4	0.67	2.70	63.6	20.4
70°		54.3	36.0	0.67	2.89	63.8	18.8
80°		53.4	35.7	0.67	3.09	63.9	17.3
90°		54.3	36.0	0.66	2.89	64.1	18.8
100°		55.1	36.4	0.66	2.70	64.3	20.4
110°		56.0	36.8	0.66	2.50	64.5	22.4
50°	85° DB 71° WB	60.0	38.1	0.63	2.54	68.7	23.7
60°		59.1	37.7	0.64	2.74	68.4	21.6
70°		58.2	37.3	0.64	2.93	68.2	19.8
80°		57.2	36.9	0.64	3.13	67.9	18.3
90°		58.2	37.3	0.64	2.93	68.2	19.8
100°		59.1	37.7	0.64	2.74	68.4	21.6
110°		60.0	38.1	0.63	2.54	68.7	23.7

HEATING FULL LOAD

Entering Fluid Temp. (°F)	Entering Air Temp. (°F)	Total Capacity (MBtuH)	Leaving Air Temp. (°F)	Power Input (KW)	Heat of Absorption (MBtuH)	COP
25°	65°	43.5	91.8	3.24	32.4	3.9
30°		46.6	93.8	3.34	35.2	4.1
40°		49.7	95.7	3.44	38.0	4.2
50°		56.0	99.6	3.64	43.5	4.5
60°		62.2	103.4	3.85	49.1	4.7
70°		68.5	107.3	4.05	54.7	5.0
80°		74.7	111.1	4.25	60.2	5.1
25°	70°	42.5	96.2	3.33	31.2	5.3
30°		45.6	98.1	3.43	33.9	5.5
40°		48.6	100.0	3.53	36.6	4.0
50°		54.7	103.8	3.74	42.0	4.3
60°		60.8	107.6	3.95	47.4	4.5
70°		66.9	111.3	4.16	52.7	4.8
80°		73.0	115.1	4.37	58.1	5.0
25°	75°	43.0	112.0	3.73	30.2	3.4
30°		46.1	114.7	3.85	32.9	3.5
40°		49.2	117.3	3.97	35.6	3.6
50°		55.3	122.7	4.20	41.0	3.9
60°		61.5	128.0	4.43	46.4	4.1
70°		67.7	133.3	4.67	51.7	4.2
80°		73.8	138.6	4.90	57.1	4.4

Part Load Capacities based upon rated flow of 5 GPM water at 1150 CFM airflow.

COOLING PART LOAD

Entering Fluid Temp. (°F)	Entering Air Temp. (°F)	Total Capacity (MBtuH)	Sensible Capacity (MBtuH)	Sensible to Total Ratio	Power Input (KW)	Heat of Rejection (MBtuH)	EER
50°	70° DB 59° WB	36.1	27.2	0.75	1.25	40.4	28.9
60°		35.9	27.0	0.75	1.44	40.8	24.9
70°		35.7	26.7	0.75	1.63	41.3	21.9
80°		35.5	26.5	0.75	1.82	41.7	19.5
90°		35.3	26.2	0.74	2.01	42.1	17.5
100°		35.0	25.9	0.74	2.20	42.5	15.9
110°		34.8	25.7	0.74	2.39	43.0	14.6
50°	75° DB 63° WB	38.9	28.4	0.73	1.27	43.2	30.7
60°		38.6	28.1	0.73	1.46	43.6	26.5
70°		38.4	27.8	0.72	1.65	44.0	23.2
80°		38.2	27.5	0.72	1.84	44.5	20.7
90°		37.9	27.3	0.72	2.04	44.9	18.6
100°		37.7	27.0	0.72	2.23	45.3	16.9
110°		37.4	26.7	0.71	2.42	45.7	15.5
50°	80° DB 67° WB	41.7	29.4	0.71	1.28	46.1	32.5
60°		41.5	29.2	0.70	1.48	46.5	28.1
70°		41.2	28.9	0.70	1.67	46.9	23.8
80°		41.0	28.6	0.70	1.87	47.3	21.9
90°		40.7	28.3	0.69	2.06	47.8	20.1
100°		40.5	28.0	0.69	2.26	48.2	18.2
110°		40.2	27.7	0.69	2.45	48.6	16.4
50°	85° DB 71° WB	44.7	30.5	0.68	1.30	49.2	34.4
60°		44.5	30.2	0.68	1.50	49.6	29.6
70°		44.2	29.9	0.68	1.70	50.0	26.0
80°		43.9	29.6	0.67	1.90	50.4	23.2
90°		43.6	29.3	0.67	2.09	50.8	20.8
100°		43.4	29.0	0.67	2.29	51.2	18.9
110°		43.1	28.7	0.67	2.49	51.6	17.3

HEATING PART LOAD

Entering Fluid Temp. (°F)	Entering Air Temp. (°F)	Total Capacity (MBtuH)	Leaving Air Temp. (°F)	Power Input (KW)	Heat of Absorption (MBtuH)	COP
25°	65°	30.3	83.7	2.13	23.1	4.2
30°		32.6	85.1	2.16	25.3	4.4
40°		34.9	86.5	2.19	27.4	4.7
50°		39.5	89.4	2.25	31.8	5.1
60°		44.0	92.2	2.32	36.1	5.6
70°		48.6	95.0	2.38	40.5	6.0
80°		53.2	97.8	2.44	44.8	6.4
25°	70°	29.7	95.5	2.19	22.2	6.8
30°		31.9	97.5	2.22	24.3	7.2
40°		34.1	99.4	2.25	26.4	7.6
50°		38.6	103.2	2.31	30.7	8.0
60°		43.1	107.1	2.38	34.9	8.4
70°		47.5	110.9	2.44	39.2	8.8
80°		52.0	114.8	2.51	43.4	9.2
25°	75°	30.0	100.8	2.45	21.6	3.6
30°		32.2	102.8	2.49	23.7	3.8
40°		34.5	104.7	2.53	25.9	4.0
50°		39.0	108.6	2.60	30.1	4.4
60°		43.5	112.5	2.67	34.4	4.8
70°		48.0	116.4	2.74	38.7	5.1
80°		52.6	120.3	2.81	42.9	5.5

GTC60S1 Matched with GTA4860UD1-A Coil

Full Load Capacities based upon rated flow of 15 GPM of 15% methanol/mass at 1800 CFM airflow.

COOLING FULL LOAD

Entering Fluid Temp. (°F)	Entering Air Temp. (°F)	Total Capacity (MBtuH)	Sensible Capacity (MBtuH)	Sensible to Total Ratio	Power Input (KW)	Heat of Rejection (MBtuH)	EER
50°	70° DB 59° WB	59.7	42.8	0.72	2.79	69.2	21.4
60°		57.1	41.8	0.73	3.19	68.0	17.9
70°		54.5	40.8	0.75	3.59	66.7	15.2
80°		51.9	39.8	0.77	3.99	65.5	13.0
90°		49.2	38.8	0.79	4.39	64.2	11.2
100°		46.6	37.8	0.81	4.78	63.0	9.7
110°		44.0	36.8	0.84	5.18	61.7	8.5
50°	75° DB 63° WB	64.2	44.6	0.69	2.82	73.8	22.8
60°		61.4	43.6	0.71	3.23	72.4	19.0
70°		58.6	42.5	0.73	3.63	71.0	16.1
80°		55.8	41.5	0.74	4.04	69.6	13.8
90°		53.0	40.4	0.76	4.45	68.2	11.9
100°		50.1	39.4	0.79	4.86	66.7	10.3
110°		47.3	38.4	0.81	5.27	65.3	9.0
50°	80° DB 67° WB	68.9	46.3	0.67	2.87	78.7	24.0
60°		65.9	45.2	0.69	3.28	77.1	20.1
70°		62.9	44.1	0.70	3.68	75.5	17.1
80°		59.9	43.0	0.72	4.09	73.9	14.6
90°		56.9	42.0	0.74	4.50	72.2	12.6
100°		53.8	40.9	0.76	4.91	70.6	11.0
110°		50.8	39.8	0.78	5.32	69.0	9.6
50°	85° DB 71° WB	73.9	47.9	0.65	2.91	83.8	25.4
60°		70.7	46.8	0.66	3.32	82.0	21.3
70°		67.4	45.7	0.68	3.74	80.2	18.0
80°		64.2	44.5	0.69	4.15	78.4	15.5
90°		60.9	43.4	0.71	4.57	76.5	13.3
100°		57.7	42.3	0.73	4.98	74.7	11.6
110°		54.5	41.2	0.76	5.39	72.9	10.1

HEATING FULL LOAD

Entering Fluid Temp. (°F)	Entering Air Temp. (°F)	Total Capacity (MBtuH)	Leaving Air Temp. (°F)	Power Input (KW)	Heat of Absorption (MBtuH)	COP
25°	65°	46.4	88.9	3.85	32.8	3.5
30°		49.6	90.5	3.95	35.7	3.7
40°		55.8	93.7	4.14	41.3	3.9
50°		62.1	96.9	4.33	46.9	4.2
60°		68.4	100.2	4.52	52.5	4.4
70°		74.6	103.4	4.72	58.1	4.6
80°		80.9	106.6	4.91	63.7	4.9
25°	70°	45.4	93.4	3.96	31.9	3.4
30°		48.5	94.9	4.05	34.6	3.5
40°		54.6	98.1	4.25	40.1	3.8
50°		60.7	101.2	4.45	45.5	4.0
60°		66.8	104.4	4.65	51.0	4.2
70°		73.0	107.5	4.84	56.4	4.4
80°		79.1	110.7	5.04	61.9	4.6
25°	75°	45.9	98.6	4.44	30.9	3.0
30°		49.0	100.2	4.55	33.6	3.2
40°		55.2	103.4	4.77	38.9	3.4
50°		61.4	106.6	5.00	44.2	3.6
60°		67.6	109.8	5.22	49.4	3.8
70°		73.8	112.9	5.44	54.7	4.0
80°		79.9	116.1	5.66	60.0	4.2

Part Load Capacities based upon rated flow of 15 GPM of 15% methanol/mass at 1300 CFM airflow.

COOLING PART LOAD

Entering Fluid Temp. (°F)	Entering Air Temp. (°F)	Total Capacity (MBtuH)	Sensible Capacity (MBtuH)	Sensible to Total Ratio	Power Input (KW)	Heat of Rejection (MBtuH)	EER
50°	70° DB 59° WB	44.8	30.7	0.69	1.50	49.9	29.8
60°		42.6	30.1	0.71	1.84	48.8	23.2
70°		40.4	29.5	0.73	2.17	47.8	18.6
80°		38.2	28.9	0.76	2.50	46.8	15.3
90°		36.1	28.3	0.78	2.84	45.7	12.7
100°		33.9	27.7	0.82	3.17	44.7	10.7
110°		31.7	27.0	0.85	3.50	43.7	9.1
50°	75° DB 63° WB	48.1	32.0	0.66	1.51	53.3	31.8
60°		45.8	31.4	0.68	1.86	52.1	24.7
70°		43.5	30.7	0.71	2.20	51.0	19.8
80°		41.1	30.1	0.73	2.54	49.8	16.2
90°		38.8	29.4	0.76	2.88	48.6	13.5
100°		36.4	28.8	0.79	3.22	47.4	11.3
110°		34.1	28.2	0.83	3.56	46.3	9.6
50°	80° DB 67° WB	51.7	33.2	0.63	1.54	57.0	26.9
60°		49.2	32.5	0.66	1.88	55.6	23.9
70°		46.7	31.9	0.68	2.23	54.3	21.0
80°		44.2	31.2	0.71	2.57	52.9	18.0
90°		41.6	30.5	0.74	2.91	51.6	15.0
100°		39.1	29.9	0.76	3.25	50.2	12.0
110°		36.6	29.2	0.79	3.59	48.9	9.1
50°	85° DB 71° WB	55.4	34.4	0.62	1.57	60.7	35.4
60°		52.7	33.7	0.64	1.91	59.2	27.6
70°		50.0	33.0	0.66	2.26	57.7	22.1
80°		47.3	32.3	0.68	2.61	56.2	18.2
90°		44.6	31.6	0.71	2.95	54.7	15.1
100°		41.9	30.9	0.74	3.30	53.2	12.7
110°		39.2	30.2	0.77	3.65	51.7	10.8

HEATING PART LOAD

Entering Fluid Temp. (°F)	Entering Air Temp. (°F)	Total Capacity (MBtuH)	Leaving Air Temp. (°F)	Power Input (KW)	Heat of Absorption (MBtuH)	COP
25°	65°	30.5	86.7	2.78	20.6	3.2
30°		33.1	88.6	2.83	23.1	3.4
40°		38.4	92.4	2.92	28.1	3.8
50°		43.8	96.2	3.02	33.2	4.2
60°		49.1	100.0	3.11	38.2	4.6
70°		54.4	103.7	3.21	43.2	5.0
80°		59.7	107.5	3.30	48.2	5.3
25°	70°	29.8	91.2	2.86	20.0	3.1
30°		32.4	93.1	2.91	22.5	3.3
40°		37.6	96.8	3.00	27.3	3.7
50°		42.8	100.5	3.10	32.2	4.0
60°		48.0	104.2	3.20	37.1	4.4
70°		53.2	107.9	3.29	41.9	4.7
80°		58.4	111.6	3.39	46.8	5.1
25°	75°	30.1	96.4	3.21	19.4	2.8
30°		32.7	98.3	3.26	21.8	2.9
40°		38.0	102.1	3.37	26.5	3.3
50°		43.2	105.8	3.48	31.2	3.6
60°		48.5	109.5	3.59	36.0	3.9
70°		53.8	113.3	3.70	40.7	4.3
80°		59.0	117.0	3.81	45.4	4.6

GTC60S1 Matched with GTA4860UD1-A Coil

Full Load Capacities based upon rated flow of 9 GPM water at 1800 CFM airflow.

COOLING FULL LOAD

Entering Fluid Temp. (°F)	Entering Air Temp. (°F)	Total Capacity (MBtuH)	Sensible Capacity (MBtuH)	Sensible to Total Ratio	Power Input (KW)	Heat of Rejection (MBtuH)	EER
50°	70° DB 59° WB	53.9	40.0	0.74	2.71	63.1	19.9
60°		53.8	40.4	0.75	3.00	64.0	17.9
70°		53.7	40.7	0.76	3.29	64.9	16.3
80°		53.6	41.1	0.77	3.58	65.8	15.0
90°		53.7	40.7	0.76	3.29	64.9	16.3
100°		53.8	40.4	0.75	3.00	64.0	17.9
110°		53.9	40.0	0.74	2.71	63.1	19.9
50°	75° DB 63° WB	57.9	41.6	0.72	2.75	67.3	21.1
60°		57.9	42.0	0.76	3.04	68.2	19.0
70°		57.8	42.4	0.75	3.33	69.1	17.3
80°		57.7	42.8	0.74	3.62	70.0	15.9
90°		57.8	42.4	0.73	3.33	69.1	17.3
100°		57.9	42.0	0.73	3.04	68.2	19.0
110°		57.9	41.6	0.72	2.75	67.3	21.1
50°	80° DB 67° WB	62.2	43.2	0.68	2.8	71.7	22.4
60°		62.1	43.6	0.70	3.08	72.6	20.2
70°		62.0	44.0	0.72	3.4	73.5	18.4
80°		61.9	44.4	0.72	3.67	74.5	16.9
90°		62.0	44.0	0.71	3.38	73.5	18.4
100°		62.1	43.6	0.70	3.08	72.6	20.2
110°		62.2	43.2	0.69	2.78	71.7	22.4
50°	85° DB 71° WB	66.7	44.7	0.67	2.82	76.3	23.6
60°		66.6	45.1	0.68	3.12	77.2	21.3
70°		66.5	45.5	0.68	3.42	78.2	19.4
80°		66.4	45.9	0.69	3.73	79.1	17.8
90°		66.5	45.5	0.68	3.42	78.2	19.4
100°		66.6	45.1	0.68	3.12	77.2	21.3
110°		66.7	44.7	0.67	2.82	76.3	23.6

HEATING FULL LOAD

Entering Fluid Temp. (°F)	Entering Air Temp. (°F)	Total Capacity (MBtuH)	Leaving Air Temp. (°F)	Power Input (KW)	Heat of Absorption (MBtuH)	COP
25°	65°	54.3	92.9	3.81	41.3	4.2
30°		56.8	94.2	3.91	43.5	4.3
40°		59.3	95.5	4.00	45.7	4.3
50°		64.3	98.1	4.19	50.0	4.5
60°		69.3	100.6	4.37	54.3	4.6
70°		74.3	103.2	4.56	58.7	4.8
80°		79.2	105.8	4.75	63.0	4.9
25°		70°	53.1	97.3	3.92	39.7
30°	55.5		98.6	4.01	41.8	5.1
40°	58.0		99.8	4.11	44.0	4.1
50°	62.8		102.3	4.30	48.2	4.3
60°	67.7		104.8	4.49	52.4	4.4
70°	72.6		107.3	4.68	56.6	4.6
80°	77.5		109.8	4.88	60.8	4.7
25°	75°		53.7	102.6	4.40	38.7
30°		56.2	103.9	4.51	40.8	3.7
40°		58.6	105.2	4.61	42.9	3.7
50°		63.5	107.7	4.83	47.1	3.9
60°		68.5	110.2	5.04	51.2	4.0
70°		73.4	112.7	5.26	55.4	4.1
80°		78.3	115.3	5.47	59.6	4.2

Part Load Capacities based upon rated flow of 9 GPM water at 1300 CFM airflow.

COOLING PART LOAD

Entering Fluid Temp. (°F)	Entering Air Temp. (°F)	Total Capacity (MBtuH)	Sensible Capacity (MBtuH)	Sensible to Total Ratio	Power Input (KW)	Heat of Rejection (MBtuH)	EER
50°	70° DB 59° WB	44.6	32.2	0.72	1.42	49.4	31.4
60°		42.9	31.4	0.73	1.67	48.6	25.8
70°		41.2	30.6	0.74	1.91	47.7	21.5
80°		39.5	29.8	0.75	2.16	46.8	18.3
90°		37.7	29.0	0.77	2.40	46.0	15.7
100°		36.0	28.2	0.78	2.65	45.1	13.6
110°		34.3	27.4	0.80	2.90	44.2	11.8
50°	75° DB 63° WB	48.0	33.5	0.70	1.44	52.9	33.4
60°		46.1	32.7	0.70	1.69	51.9	27.4
70°		44.3	31.8	0.72	1.94	50.9	22.9
80°		42.4	31.0	0.73	2.19	49.9	19.4
90°		40.6	30.2	0.74	2.43	48.9	16.7
100°		38.8	29.3	0.76	2.68	47.9	14.4
110°		36.9	28.5	0.77	2.93	46.9	12.6
50°	80° DB 67° WB	51.5	34.8	0.68	1.46	56.5	35.4
60°		49.5	33.9	0.68	1.71	55.4	29.0
70°		47.5	33.0	0.69	1.96	54.2	23.0
80°		45.6	32.2	0.71	2.21	53.1	20.6
90°		43.6	31.3	0.72	2.47	52.0	18.2
100°		41.6	30.4	0.73	2.72	50.9	15.7
110°		39.6	29.6	0.75	2.97	49.8	13.3
50°	85° DB 71° WB	55.2	36.0	0.65	1.48	60.2	37.4
60°		53.1	35.1	0.66	1.73	59.0	30.6
70°		51.0	34.2	0.67	1.99	57.7	25.6
80°		48.8	33.3	0.68	2.25	56.5	21.7
90°		46.7	32.4	0.69	2.50	55.3	18.7
100°		44.6	31.5	0.71	2.76	54.0	16.2
110°		42.5	30.6	0.72	3.02	52.8	14.1

HEATING PART LOAD

Entering Fluid Temp. (°F)	Entering Air Temp. (°F)	Total Capacity (MBtuH)	Leaving Air Temp. (°F)	Power Input (KW)	Heat of Absorption (MBtuH)	COP
25°	65°	29.3	85.8	2.06	22.2	4.2
30°		35.9	90.6	2.44	27.6	4.3
40°		42.6	95.3	2.83	32.9	4.4
50°		55.9	104.8	3.60	43.6	4.5
60°		69.3	114.3	4.37	54.3	4.6
70°		82.6	123.8	5.15	65.0	4.7
80°		95.9	133.3	5.92	75.7	4.7
25°		70°	28.6	84.7	2.11	21.4
30°	35.1		88.1	2.51	26.6	4.8
40°	41.6		91.4	2.91	31.7	4.2
50°	54.7		98.1	3.70	42.1	4.3
60°	67.7		104.8	4.49	52.4	4.4
70°	80.7		111.5	5.28	62.7	4.5
80°	93.8		118.2	6.08	73.0	4.6
25°	75°		28.9	95.6	2.37	20.8
30°		35.5	100.3	2.82	25.9	3.7
40°		42.1	105.0	3.26	31.0	3.8
50°		55.3	114.4	4.15	41.1	3.9
60°		68.5	123.8	5.04	51.2	4.0
70°		81.6	133.1	5.93	61.4	4.0
80°		94.8	142.5	6.83	71.5	4.1

GTA Coil Dimensions if Used Without Cabinet

GTA Coil Dimensions If Used Without Cabinet

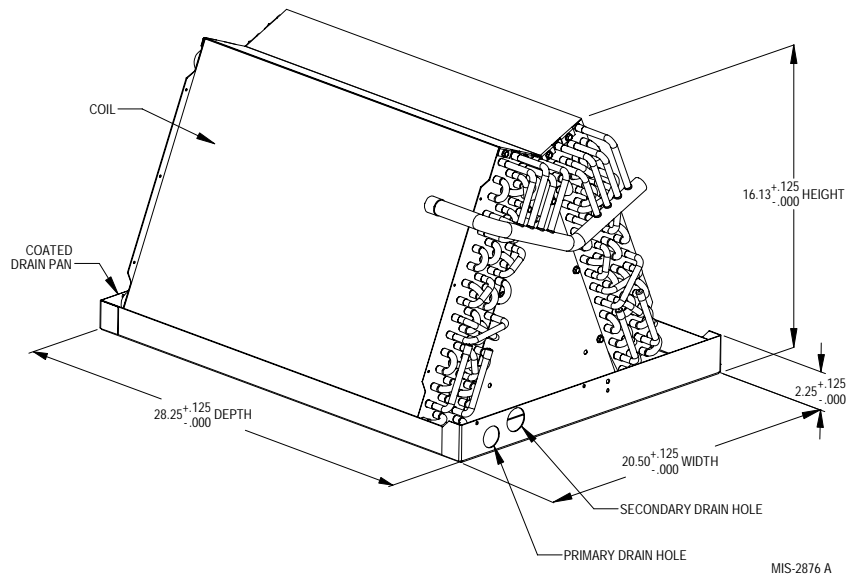

Duct Heaters for Upflow and Horizontal Installation Only (Field Installed, Separate Power Supply Required)

For Use With	Duct Heater Part Number	Heater Package	240 Volts			208 Volts			Minimum Circuit Ampacity	Maximum HACR Circuit Breaker	Field Wire Size +
			KW	Amps	BTUH	KW	Amps	BTUH			
All GTC*S1 Models	8604-080 MR812-5-1	240/208-60-1	5.0	20.8	17,065	3.75	18.0	12,799	26.0	30	#10
	8604-081 MR816-9.8-1	240/208-60-1	9.8	40.8	33,447	7.35	35.3	25,086	52.0	60	#6
	8604-082 MR1218-14.7-1	240/208-60-1	14.7	61.2	50,171	11.0	52.9	37,543	76.6	80	#4
	8604-083 MR1218-19.2-1	240/208-60-1	19.2	81.7	65,530	14.4	69.2	49,147	102.0	125	#1

+ Based upon 75°C copper wire. All wiring must conform to National Electric Code (Latest Edition) and all local codes.

Duct Heater Part Number	DIMENSIONS IN INCHES					
	A	B	C	D	E	F
8604-080	7	11.5	4.5	8	11.5	8.6
8604-081	7	15.5	4.5	9.5	11.5	8.6
8604-082	11	17.5	5.5	14.5	18	8.6
8604-083	11	17.5	5.5	14.5	18	8.6

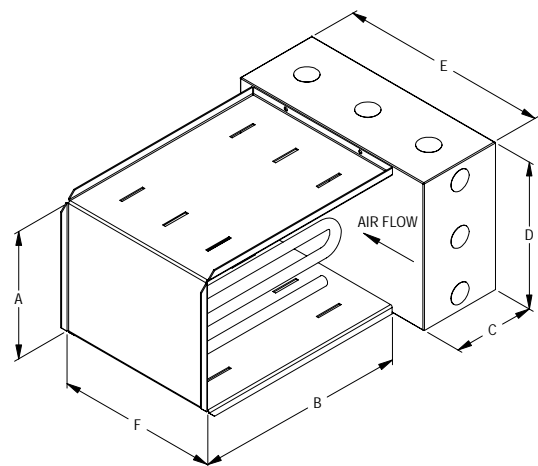

Horizontal – Left to Right Airflow (Shown)



Before purchasing this appliance, read important energy cost and efficiency information available from your retailer.

Form No.
S3443
February, 2011

Supersedes **NEW**